

Barudan

HIGH SPEED AUTOMATIC EMBROIDERY MACHINE

BENT ZN 101U

PARTS LIST

TANTO
BENT-ZN-101
HIGH SPEED AUTOMATIC EMBROIDERY MACHINE
高速自動刺繡マシン

C O N T E N T S
目 次

Machine layout (BENT-ZN)
配置図 (BENT-ZN)

- 00 Table・Frame
テーブル・フレーム
- 01A Head・Bed A
ヘッド・ベッドA
- 01B Head・Bed B
ヘッド・ベッドB
- 02A Thread cut A
糸切りA
- 02B Thread cut B
糸切りB
- 02C Thread cut C
糸切りC
- 02D Thread cut D
糸切りD
- 03 Take up lever
天秤
- 04A Needle bar A
針棒A
- 04B Needle bar B
針棒B
- 04C Needle bar C
針棒C

- 05 Jump
 ジャンプ

- 06A Thread guide A (Standard)
 糸道 A (標準)

- 06B Thread guide B (Lower thread sensorium)
 糸道 B (下糸検知)

- 07 Color change
 色換え

- 08 Drive
 駆動

- 10A H-direction pantograph drive
 H方向棒駆動

- 10B V-direction pantograph drive
 V方向棒駆動

- 11 Control
 制御

- 12 Accessories
 付属品

INDEX
索引

Machine layout (BENT-ZN)

配置図 (BENT-ZN)

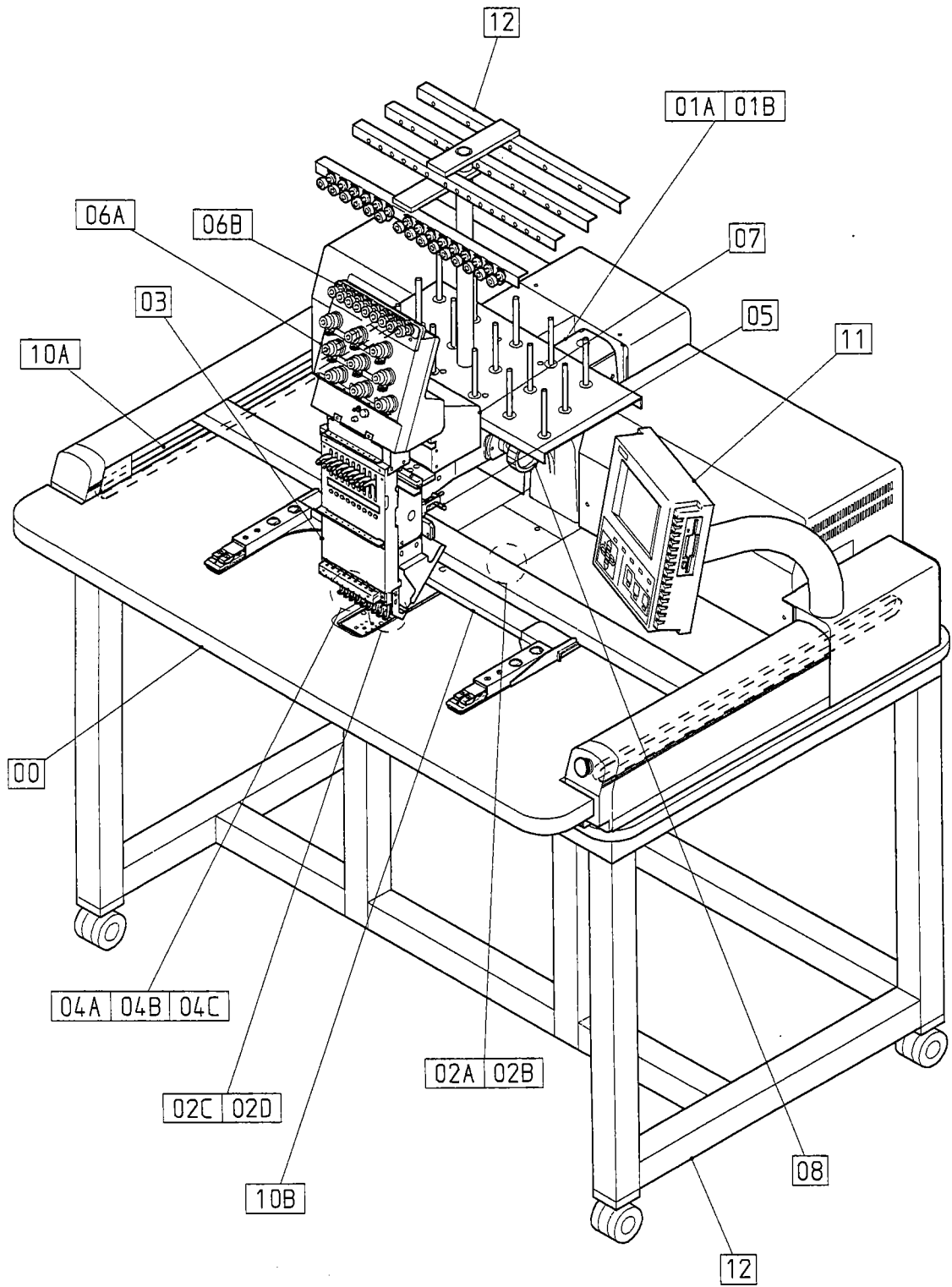

BENT-ZN

00 Table・Frame
テーブル・フレーム

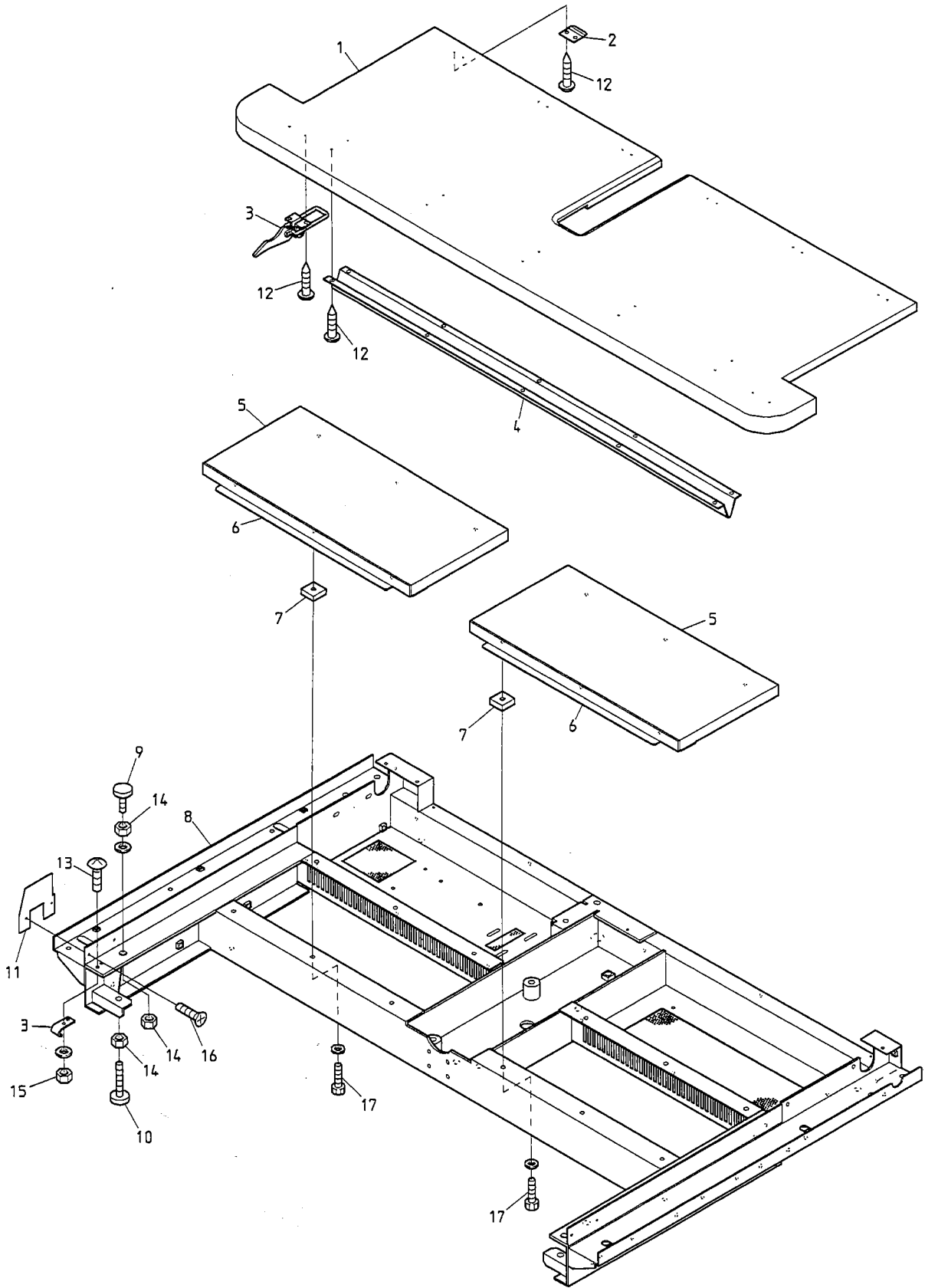

BENT-ZN

01A Head・Bed A
ヘッド・ベッドA

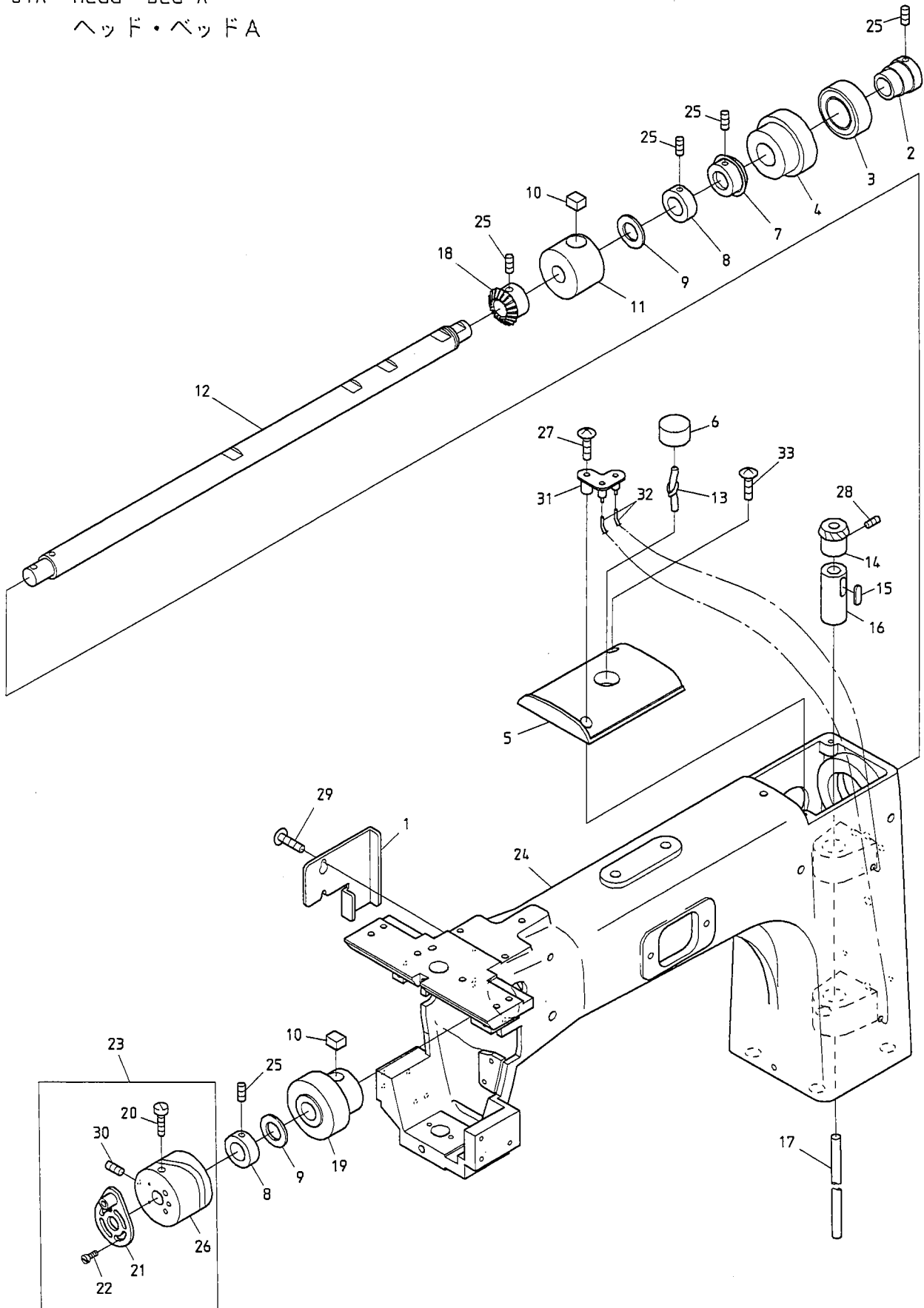

BENT-ZN

01B Head・Bed B
ヘッド・ベッドB

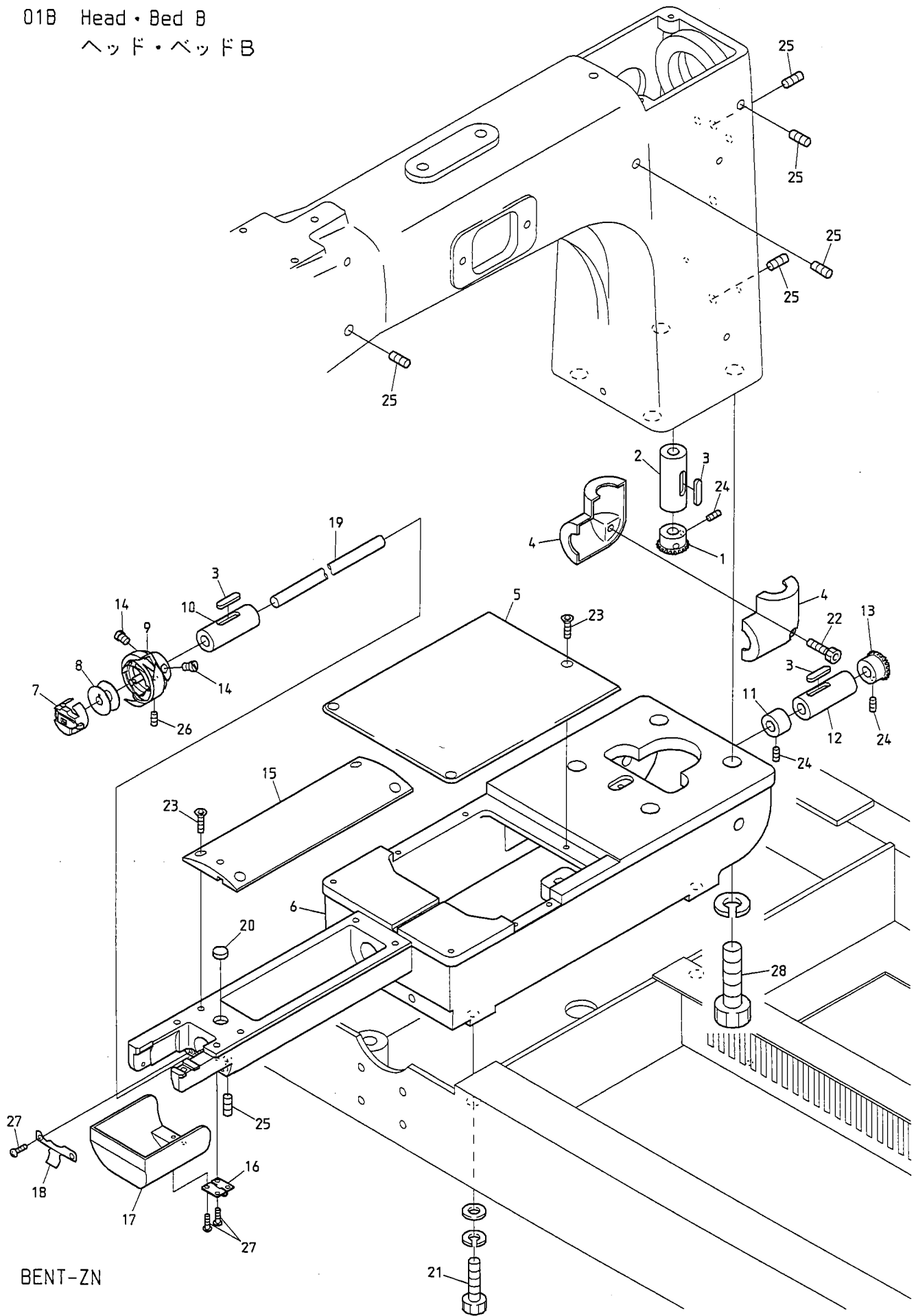

BENT-ZN

02A Thread cut A
糸切りA

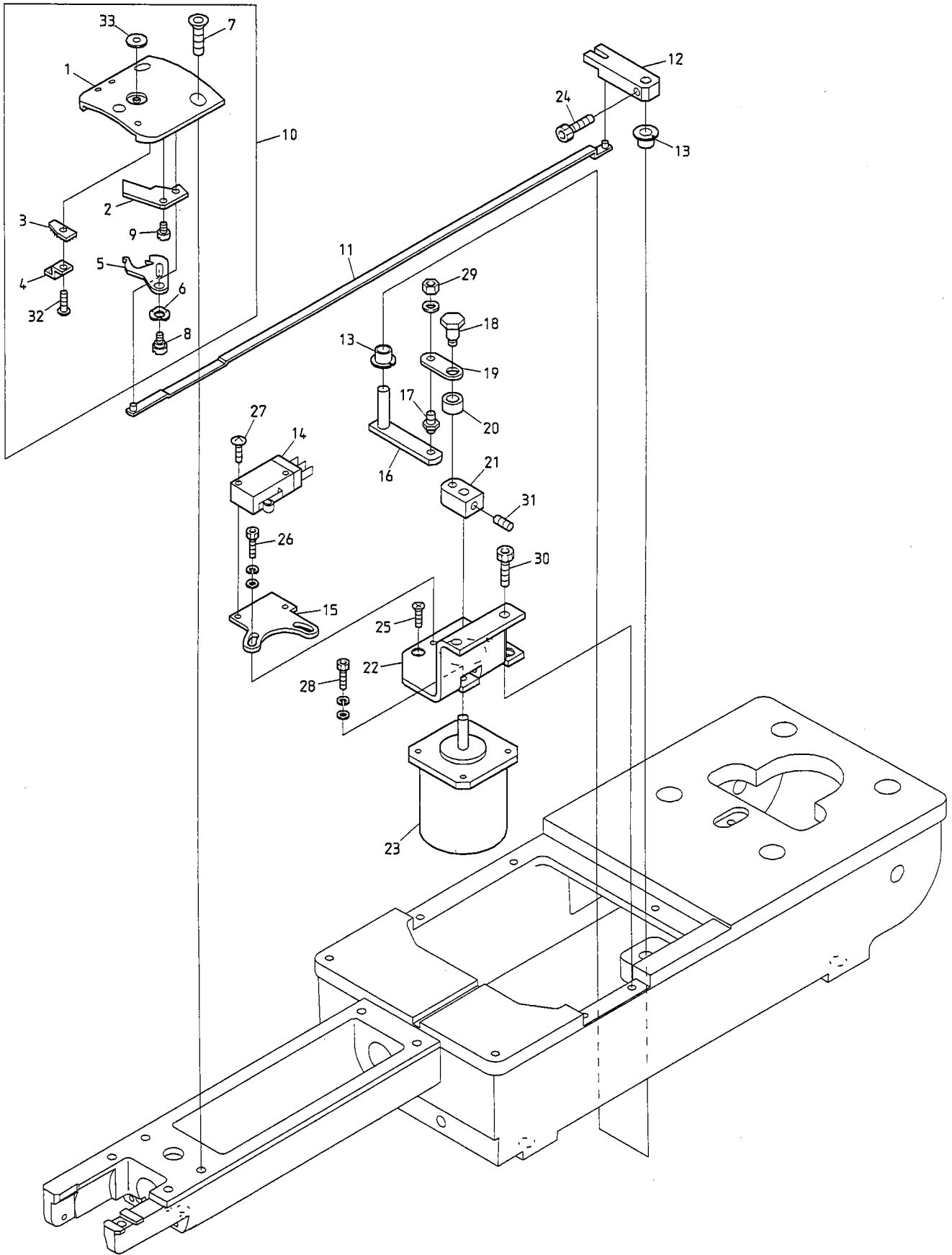

BENT-ZN

02B Thread cut B
糸切りB

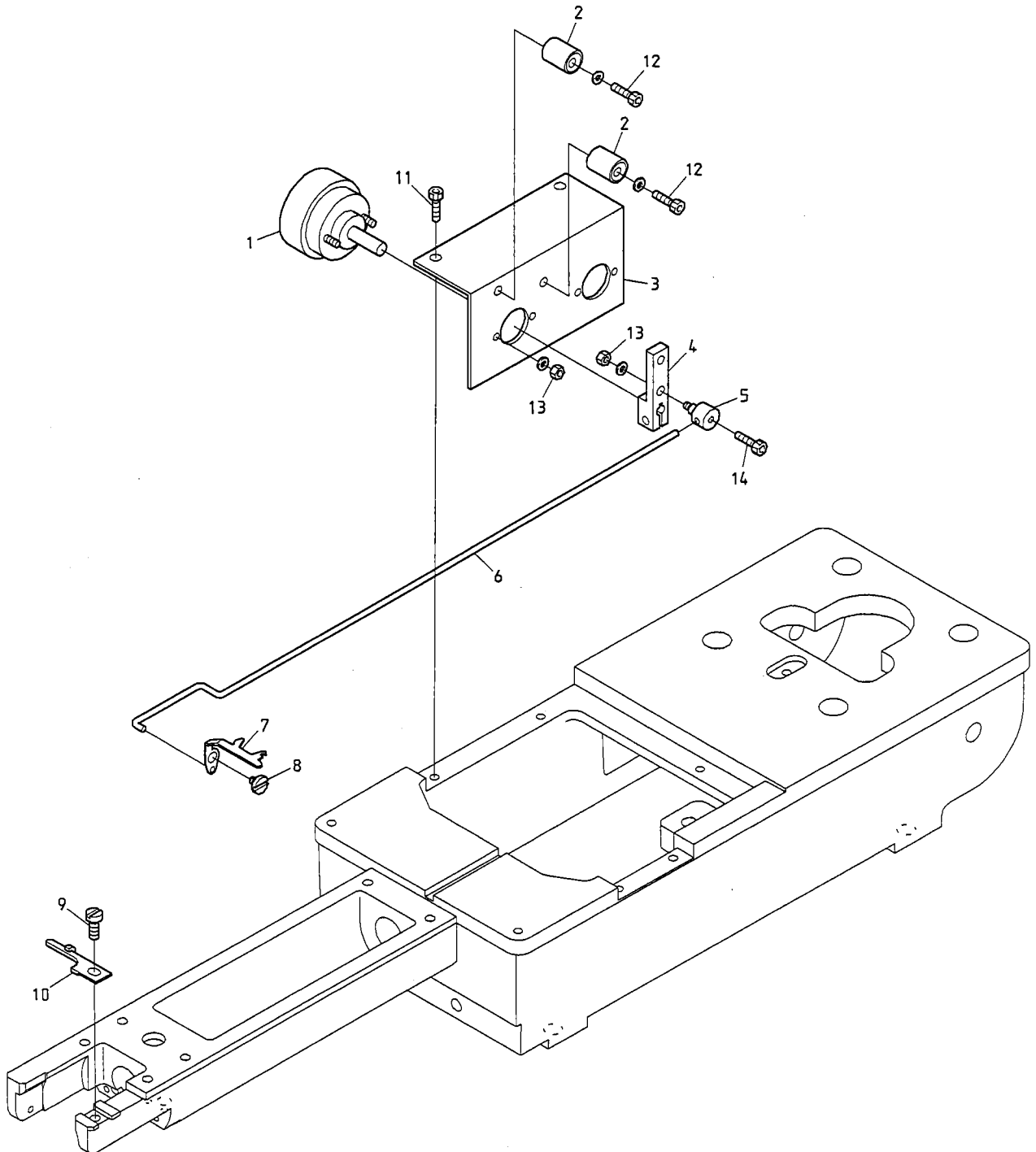

BENT-ZN

02C Thread cut C
糸切りC

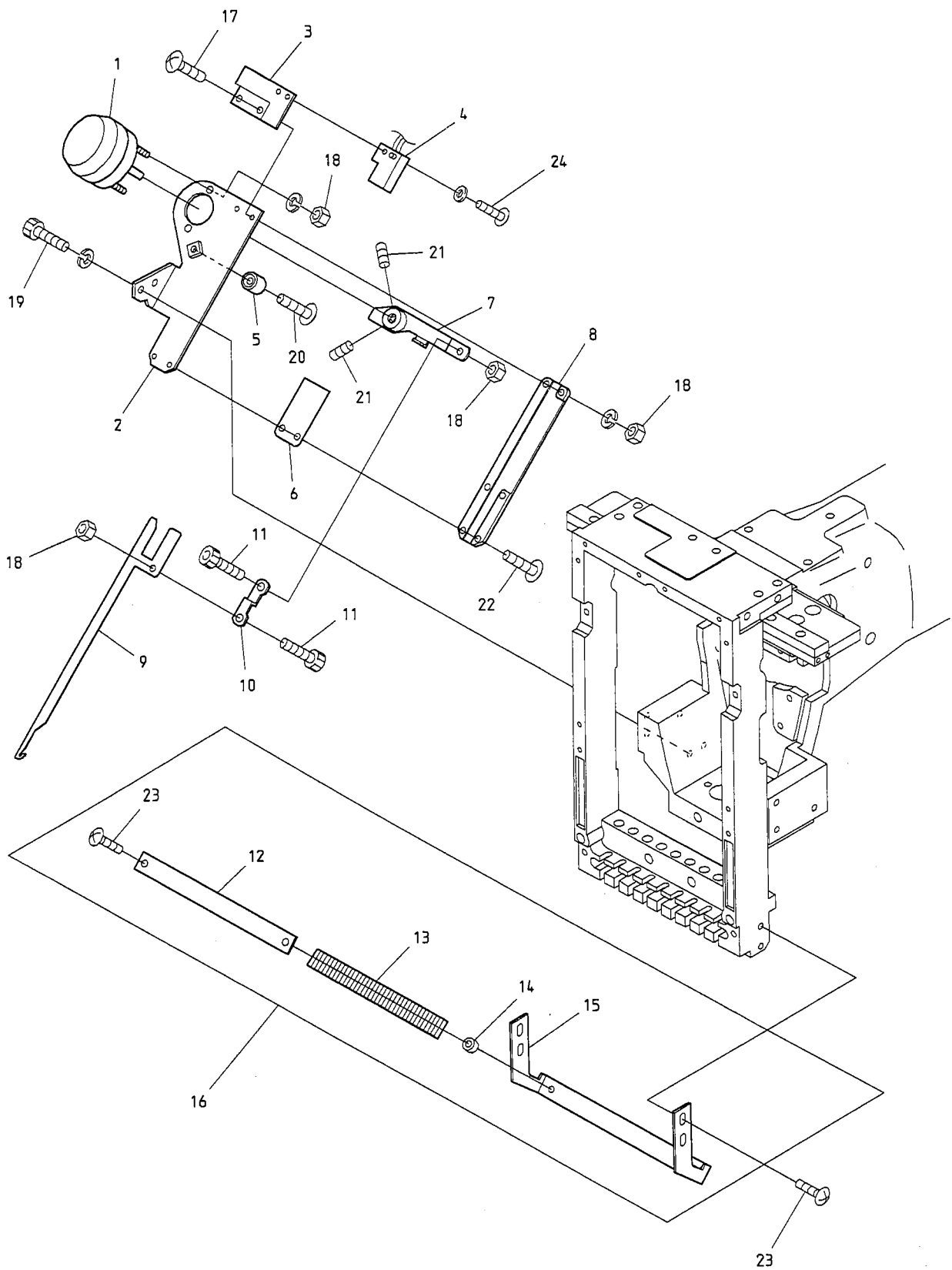

BENSME-ZN BENYME-ZN BENT-ZN
 BENRME-ZN BENBME-ZN

020 Thread cut D
系切りD

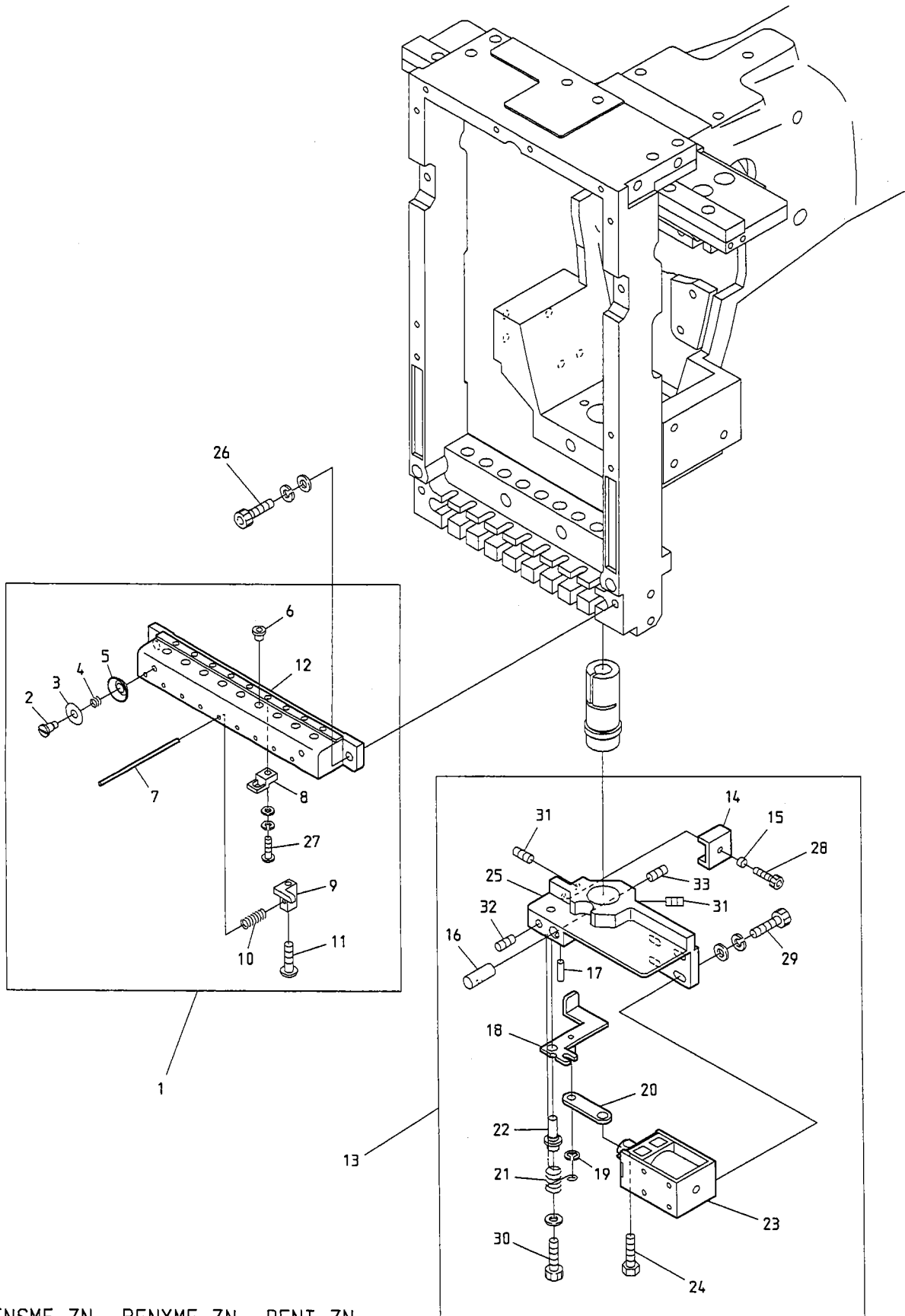

BENSME-ZN BENYME-ZN BENT-ZN
 BENRME-ZN BENBME-ZN

03 Take up lever
天秤

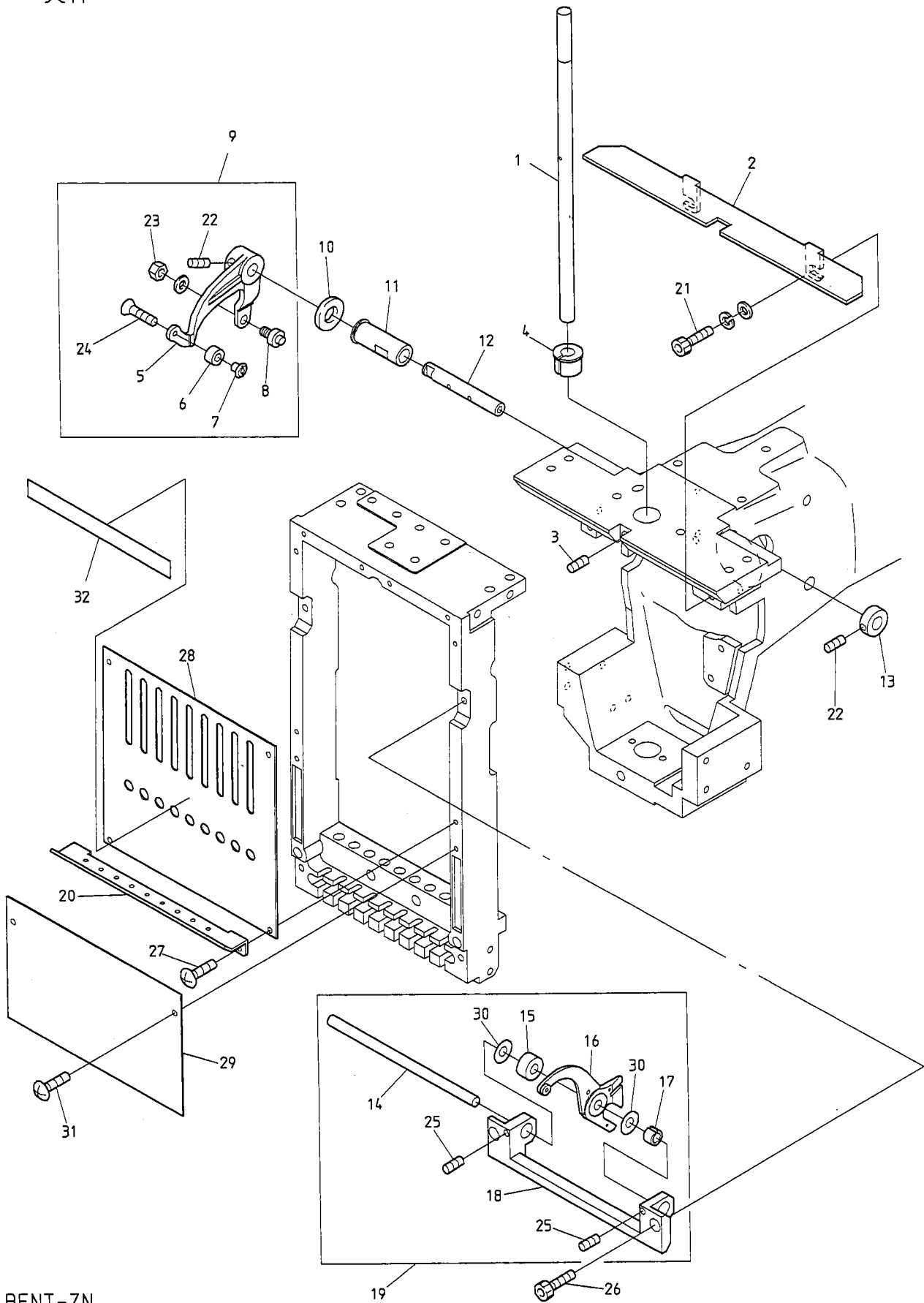

BENT-ZN

04A Needle bar A
針棒 A

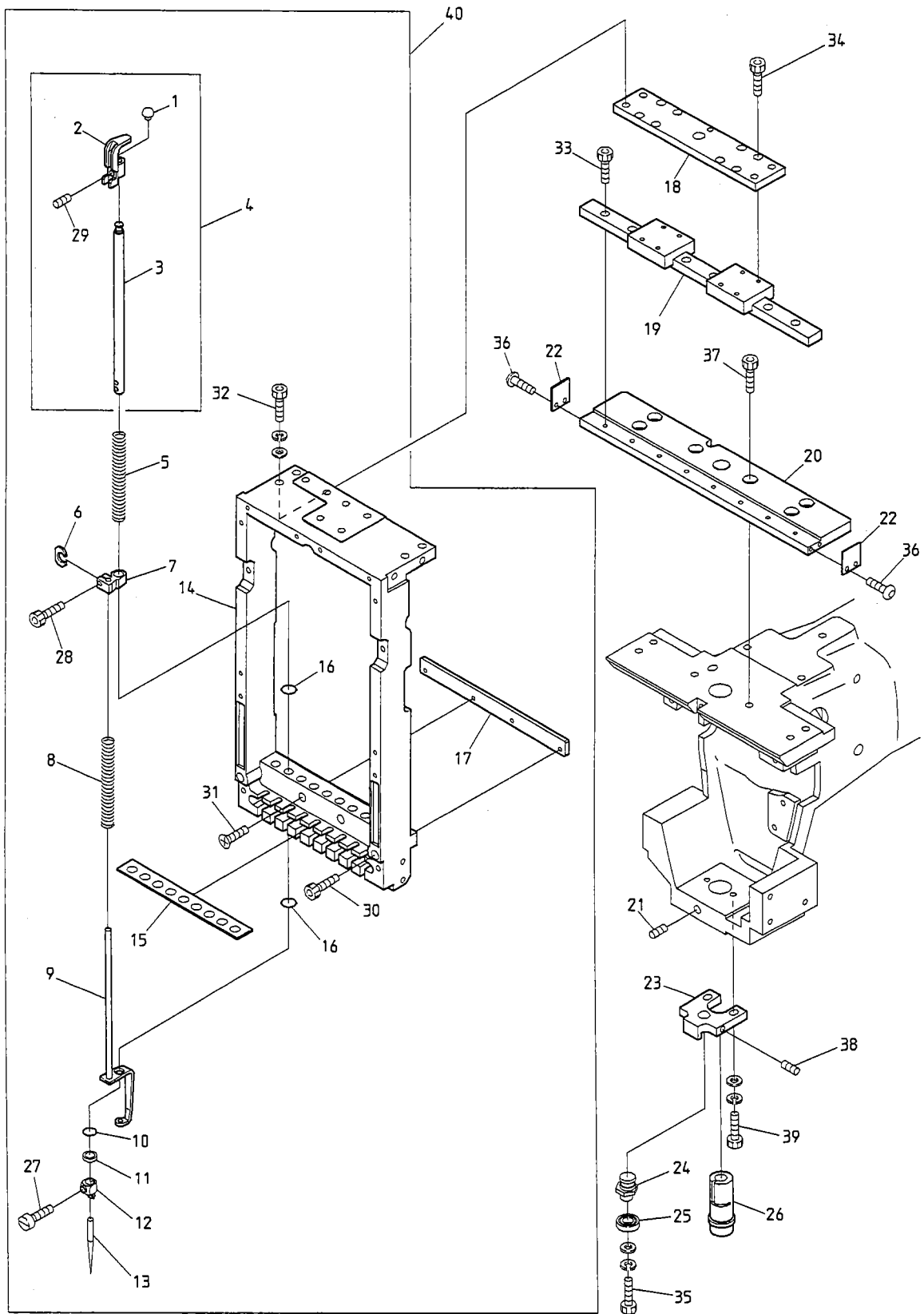

BENT-ZN

04A Needle bar A

針棒 A

ITEM	LIST No.	DESCRIPTION	部品名	Q'TY	NOTE
1	HT230130	Needle bar cap	針棒キャップ	9	
2	HT230151	Needle bar guide	針棒ガイド	9	
3	HT230041	Needle bar	針棒	9	
4	HT230810	Needle bar a'ssy	針棒 a'ssy	9	
5	HT230251	Needle bar spring	針棒バネ	9	
6	HT230263	Washer for set clamp	セットクランプ用座金	9	
7	HT230051	Cloth winder stop latch set clamp	布押えセットクランプ	9	
8	KX230250	Needle bar spring(Lower)	針棒バネ(下)	9	
9	HT230143	Pressure foot	布押え	9	
10	KF230910	O-ring(Small)	Oリング(小)	9	
11	MF230000	Washer 2.4 φ11	ジュラコンワッシャー 2.4 φ11	9	
12	HT230670	Needle clamp(With hook)	針止め(フック付)	9	
13	FN070011SNY	Needle(DBXK5-NY11S)	針(DBXK5-NY11S)	9	
14	KX230280	Slide block	スライドブロック	1	
15	KX230180	Needle bar felt	針棒フェルト	1	
16	KF230920	O-ring(Large)	Oリング(大)	18	
17	KX230040	Bearing plate	ベアリングプレート	1	
18	KX230010	LM base	LMベース	1	
19	KX230060	LM guide	LMガイド	1	
20	KX230022	Base plate	ベースプレート	1	
21	A9012053	Hex. socket set screw M6×0.75×8	六角穴付止メネジ(鋼球付) M6×0.75×8	2	
22	KX230190	LM stopper	LMストッパー	2	
23	KX230030	Bearing guide	ベアリングガイド	1	
24	KX230050	Bearing pin	ベアリングピン	1	
25	A9010065	Ball bearing 686ZZ	ボールベアリング 686ZZ	1	
26	KX230080	Driving shaft bush(Lower)	駆動軸ブッシュ(下)	1	
27	KF230240	Needle clamp screw(SM9/64 SM9/64-40)	針止めネジ(SM9/64 山40)	9	
28		Hex. socket bolt M3×8	六角穴付ボルト M3×8		
29		Hex. socket set screw M4×4	六角穴付止メネジ M4×4		
30		Hex. socket bolt M3×25	六角穴付ボルト M3×25		
31		Hex. socket flush screw M3×25	六角穴付皿ボルト M3×25		
32		Hex. socket bolt M5×16(With washers)	六角穴付ボルト M5×16(平座金、バネ座金付)		
33		Hex. socket bolt M3×8	六角穴付ボルト M3×8		
34		Hex. socket bolt M3×6	六角穴付ボルト M3×6		
35		Hex. socket bolt M4×6(With washers)	六角穴付ボルト M4×6(平座金、バネ座金付)		
36		Hex. socket button bolt M3×6	六角穴付ボタンボルト M3×6		
37		Hex. socket bolt M5×12	六角穴付ボルト M5×12		
38		Hex. socket set screw M4×12	六角穴付止メネジ(棒先) M4×12		
39		Hex. socket bolt M4×15(With washers)	六角穴付ボルト M4×15(平座金、バネ座金付)		
40	KX230300	Slide block a'ssy	スライドブロック a'ssy	1	

04B Needle bar B
針棒 B

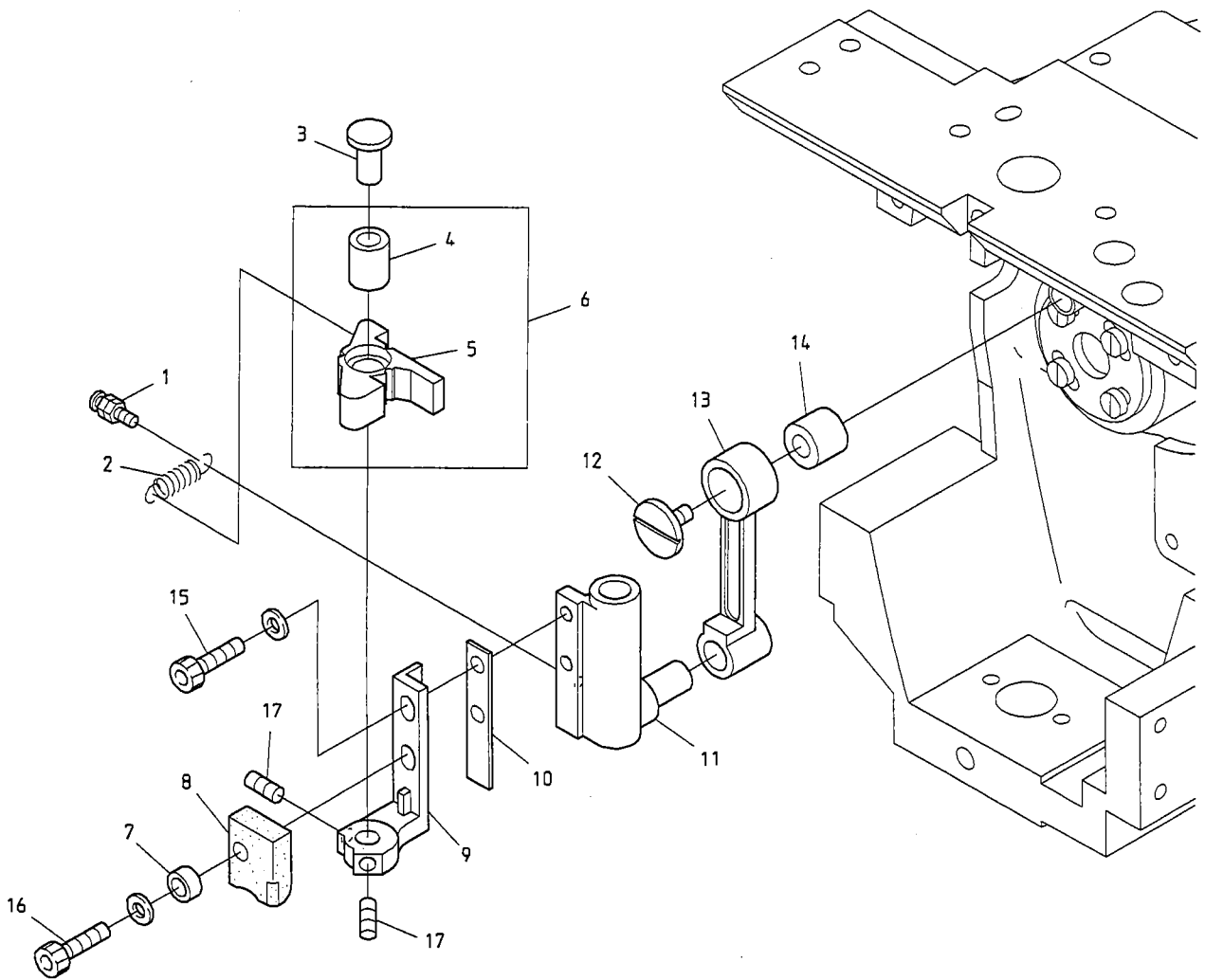

BENT-ZN

04C Needle bar C
針棒C

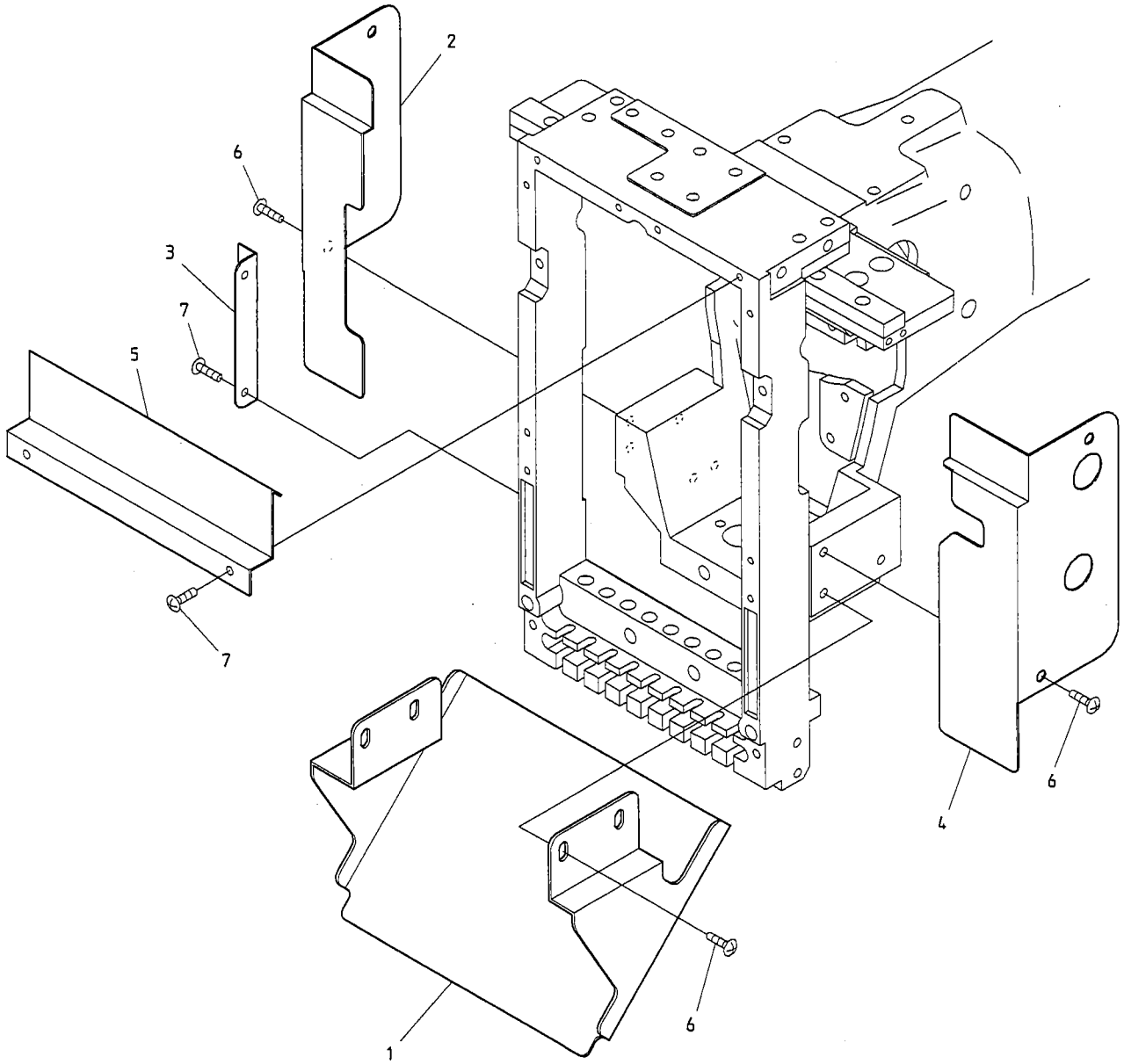

BENT-ZN

05 Jump
ジャンプ

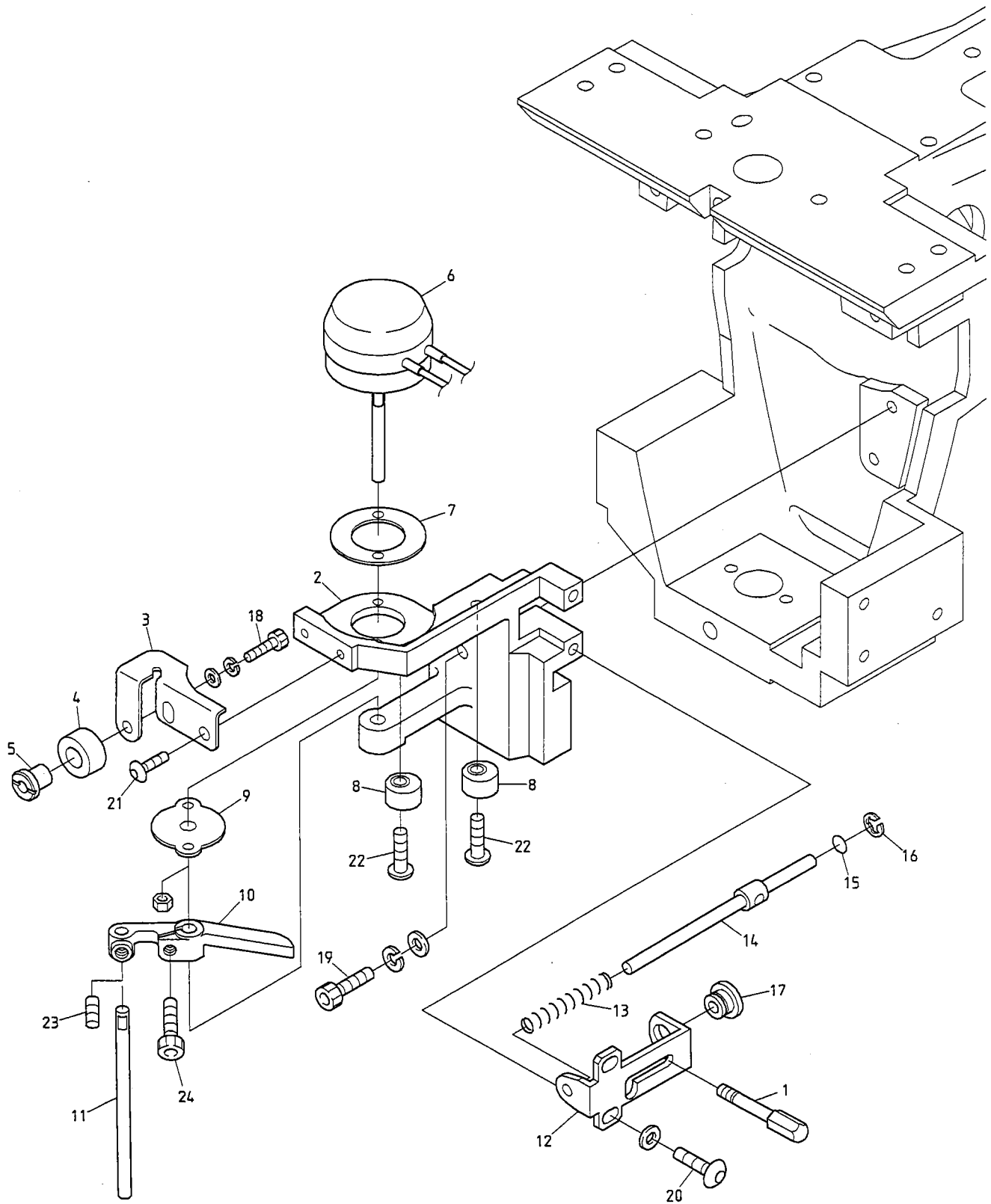

BENSME-ZN BENYME-ZN BENT-ZN
 BENRME-ZN BENBME-ZN

06A Thread guide A (Standard)
糸道A (標準)

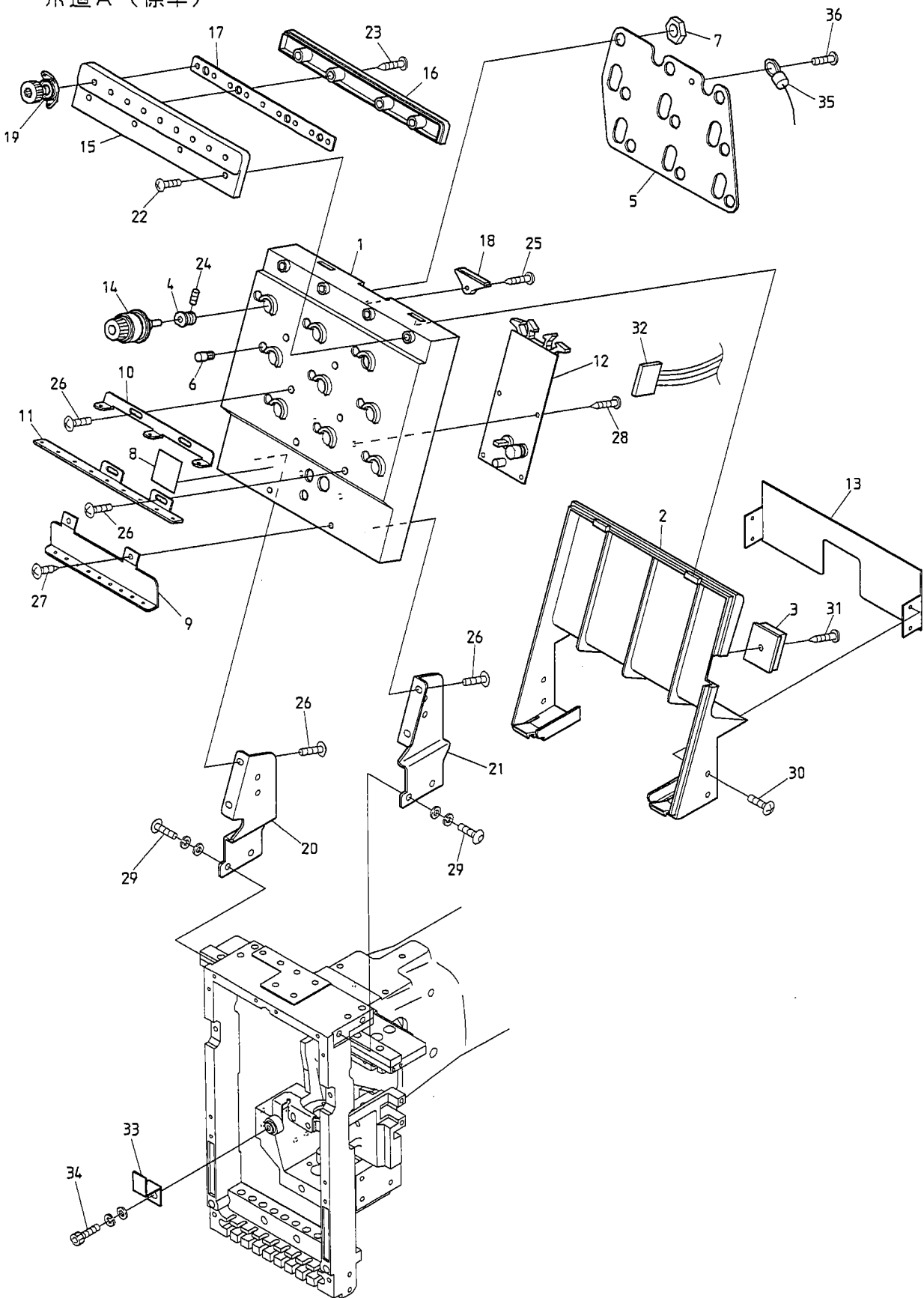

06B Thread guide B (Lower thread sensorium)
糸道B (下糸検知)

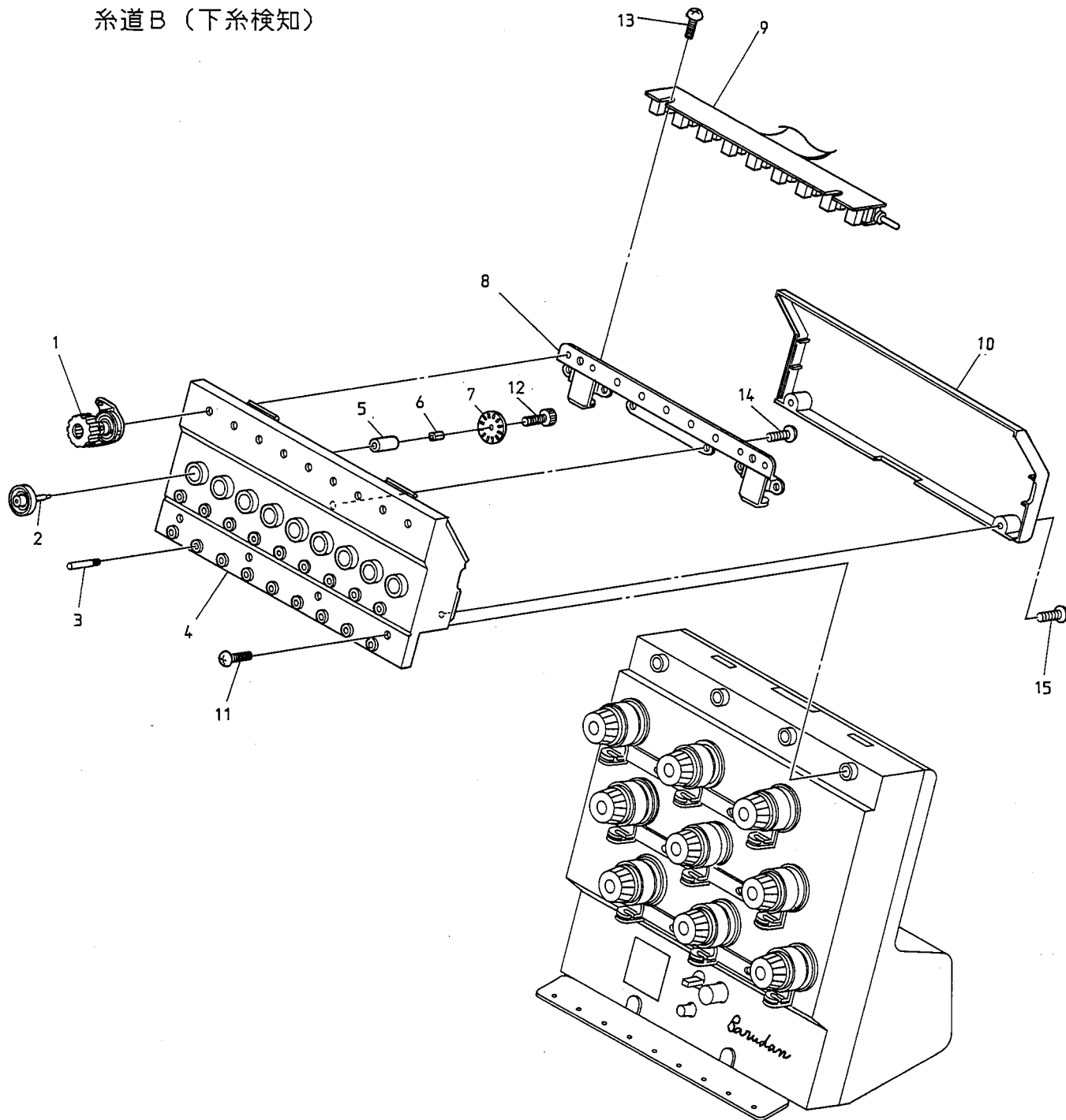

BENS-YN BENY-YN BENSME-YN BENYME-YN BENSME-ZN BENYME-ZN BENT-ZN
BENR-YN BENB-YN BENRME-YN BENBME-YN BENRME-ZN BENBME-ZN

BENSH-YN BENYH-YN BENSHE-YN BENYHE-YN
BENRH-YN BENBH-YN BENRHE-YN BENBHE-YN

07 Color change
色換え

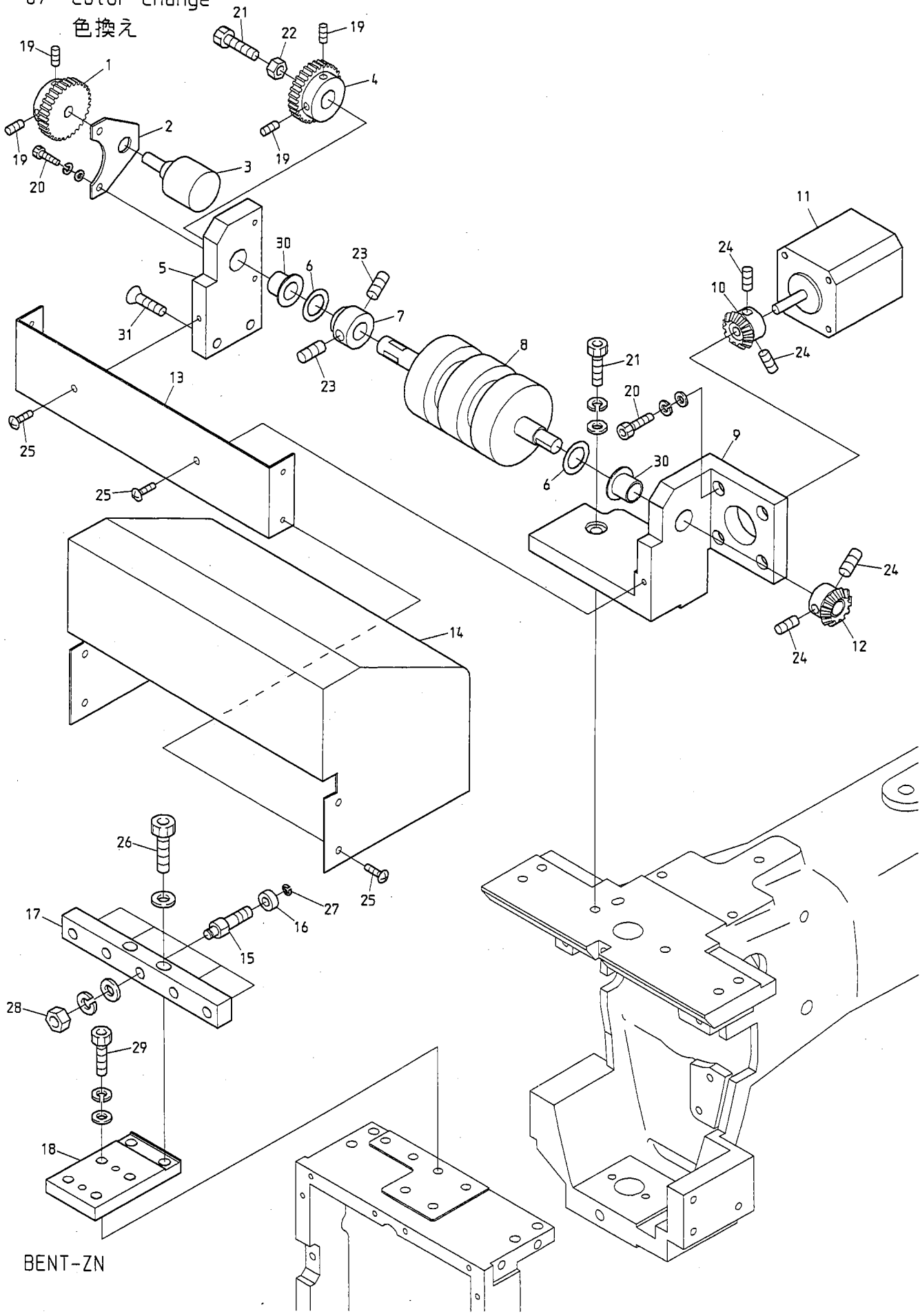

BENT-ZN

08 Drive
駆動

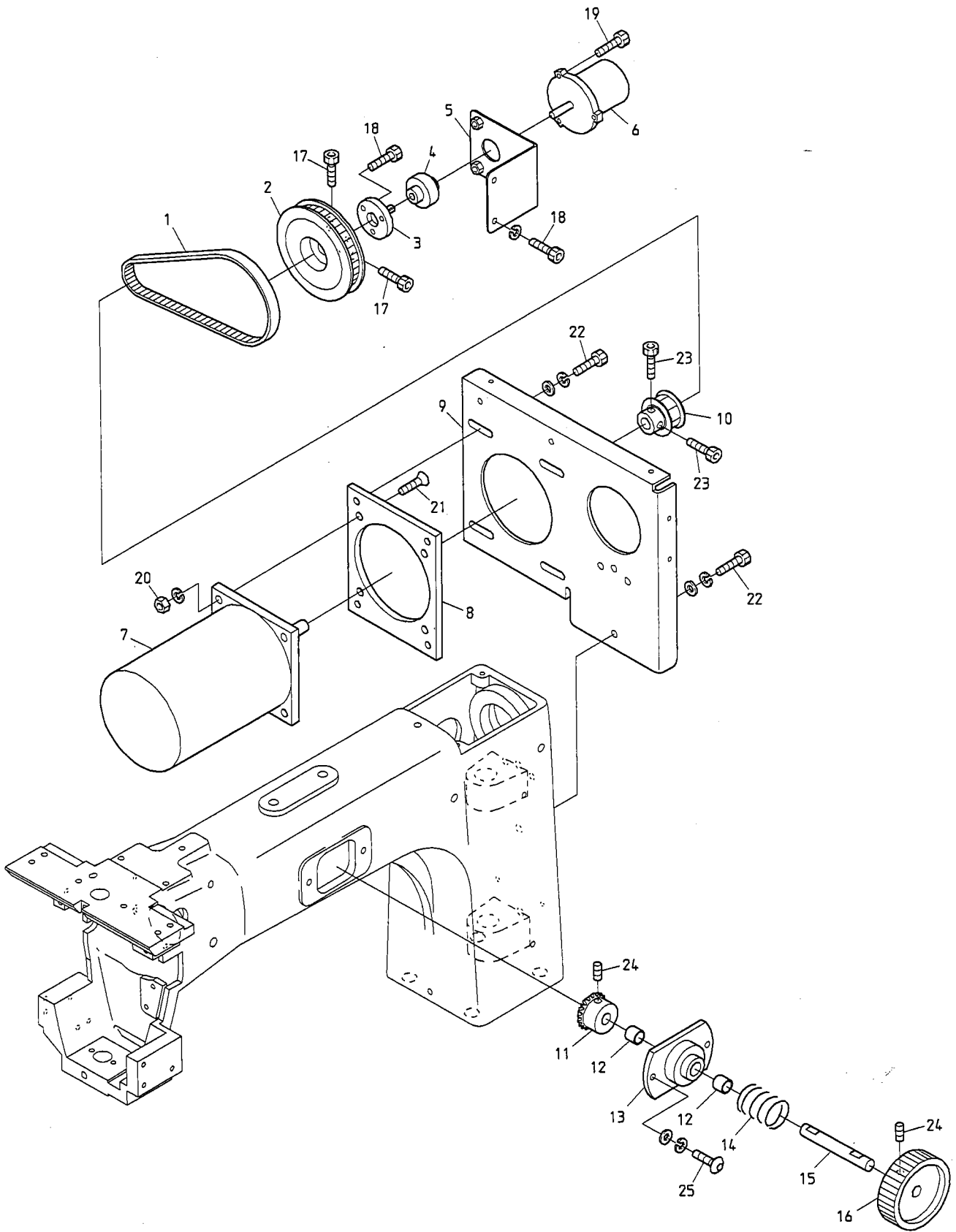

BENT-ZN

10A H-direction pantograph drive
H方向枠駆動

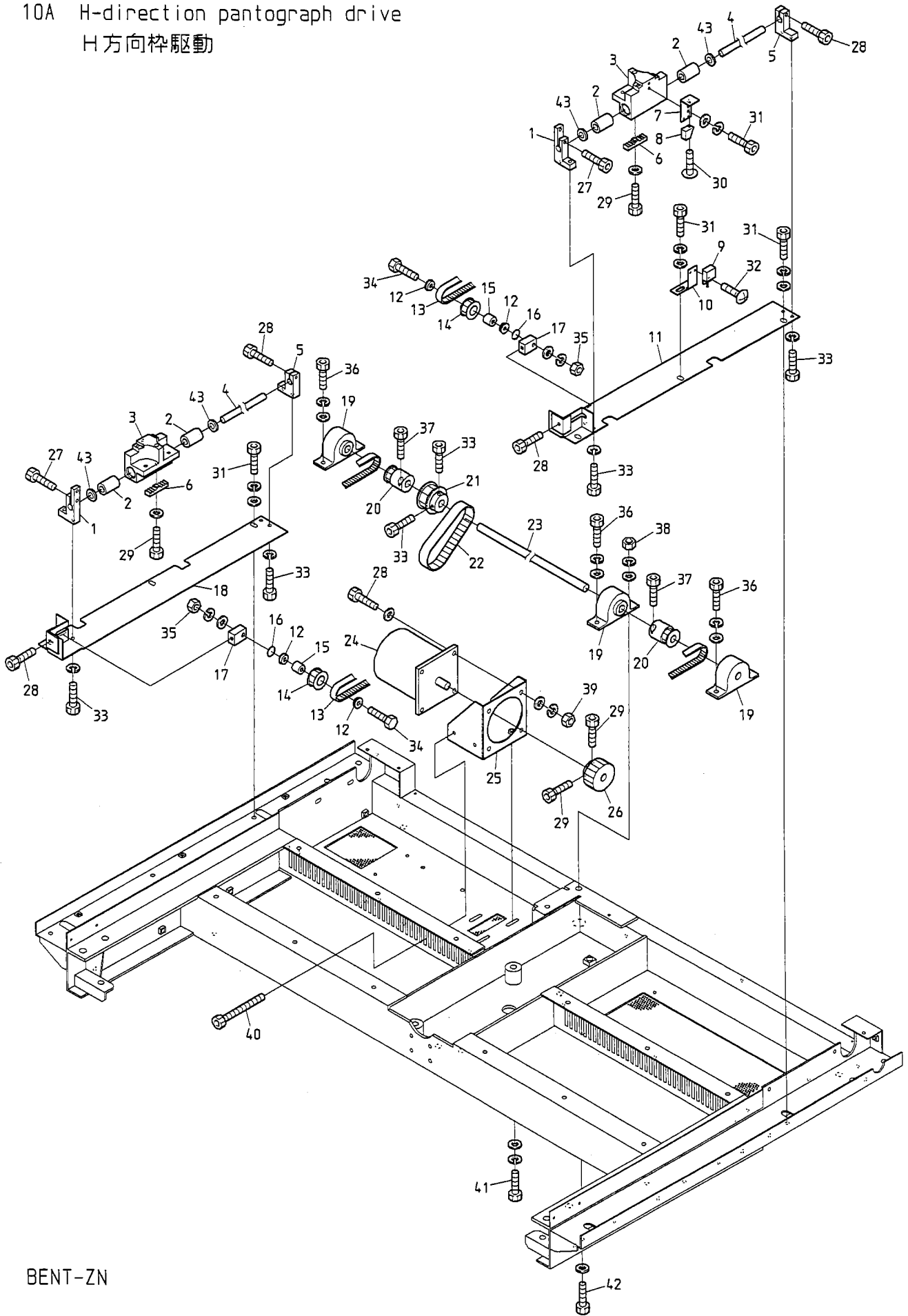

BENT-ZN

10A H-direction pantograph drive

H 方向 枠 駆 動

ITEM	LIST No.	DESCRIPTION	部品名	Q'TY	NOTE
1	MF480150	Shaft holder	シャフトホルダー	2	
2	A9011103	Metal bush(SMZ10-20)	メタルブッシュ(SMZ10-20)	4	
3	MF480161	H-shaft housing	H軸ハウジング	2	
4	A9011235	Guide shaft(SF10g6-450L)	ガイドシャフト(SF10g6-450L)	2	
5	MF481210	H-support bracket rear	Hサポートブラケット 後	2	
6	MF480190	H-belt clamp	Hベルトクランプ	2	
7	MF480340	Magnet bracket	マグネットブラケット	1	
8	A9052030	Magnet	マグネット	1	
9	A9052031	Magnetic memory promixing switch	磁気記憶近接スイッチ	1	
10	MF480330	Origin point sensor bracket	原点センサーブラケット	1	
11	MF481180	H-base bracket right	Hベースブラケット 右	1	
12	A9010039	Bearing with flange	フランジ付きベアリング	4	
13	A9020184	H-timing belt(100S5M1295)	Hタイミングベルト(100S5M1295)	2	
14	MF481240	H-timing pulley front	Hタイミングプーリー 前	2	
15	A9012406	Roll bush(6x6.5)	巻ブッシュ(6x6.5)	2	
16	A9010106	Shim-ring(SP-006050)	シムリング(SP-006050)	2	
17	MF481300	H-pulley adjust block	Hプーリーアジャストブロック	2	
18	MF481170	H-base bracket left	Hベースブラケット 左	1	
19	A9011236	Pillow block 12mm(SBPP201F)	ピロブロック 12mm(SBPP201F)	3	
20	MF481230	H-timing pulley rear	Hタイミングプーリー 後	2	
21	MF480130	H-shaft motor timing pulley	H軸モーター駆動プーリー	1	
22	A9020183	Timing belt(150S5M295)	タイミングベルト(150S5M295)	1	
23	MF481290	H-drive connecting shaft 12mm	H駆動連結シャフト 12mm	1	
24	MF480400	Pantograph drive motor	枠駆動モーター	1	
25	MF481220	H-pulse motor bracket	Hパルスモーターブラケット	1	
26	MF480140	H-shaft motor drive pulley	H軸モーター駆動プーリー	1	
27		Hex. socket bolt M4x25	六角穴付ボルト M4x25		
28		Hex. socket bolt M5x20	六角穴付ボルト M5x20		
29		Hex. socket bolt M5x15	六角穴付ボルト M5x15		
30		Truss screw M3x6	十字穴付トラス小ネジ M3x6		
31		Hex. socket bolt M6x15	六角穴付ボルト M6x15		
32		Truss screw M3x8	十字穴付トラス小ネジ M3x8		
33		Hex. socket bolt M5x12	六角穴付ボルト M5x12		
34		Hex. bolt M6x45	六角ボルト M6x45		
35		Hex. nut M6	六角ナット M6		
36		Hex. socket bolt M8x18	六角穴付ボルト M8x18		
37		Hex. socket bolt M4x15	六角穴付ボルト M4x15		
38		Hex. nut M8	六角ナット M8		
39		Hex. nut M5	六角ナット M5		
40		Hex. socket bolt M5x70	六角穴付ボルト M5x70		
41		Hex. socket bolt M5x8	六角穴付ボルト M5x8		
42		Hex. socket bolt M8x80	六角穴付ボルト M8x80		
43	A9011123	Felt seal(FLM10)	フェルトシール(FLM10)	4	

10B V-direction pantograph drive
 V方向枠駆動

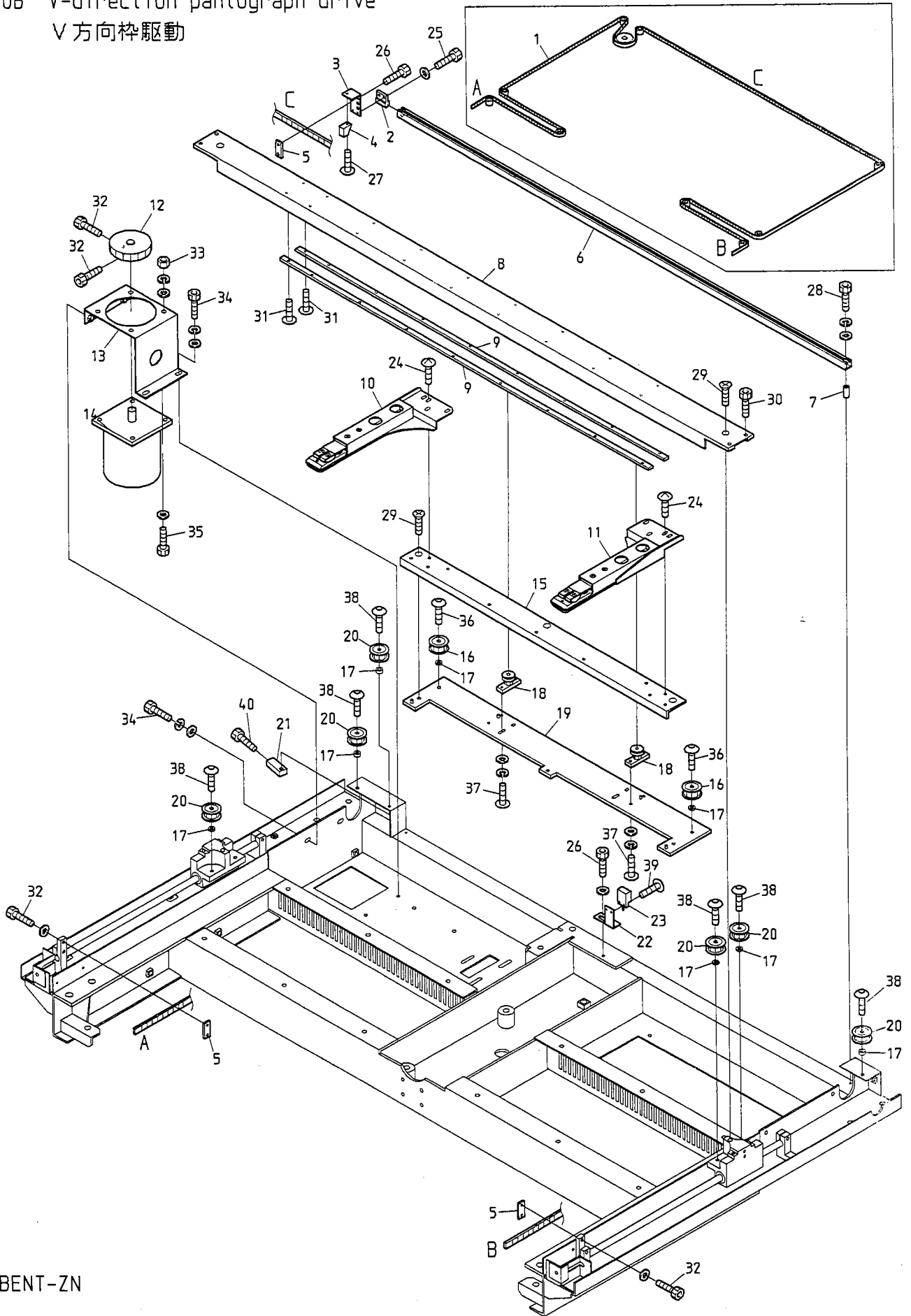

11 Control
制御

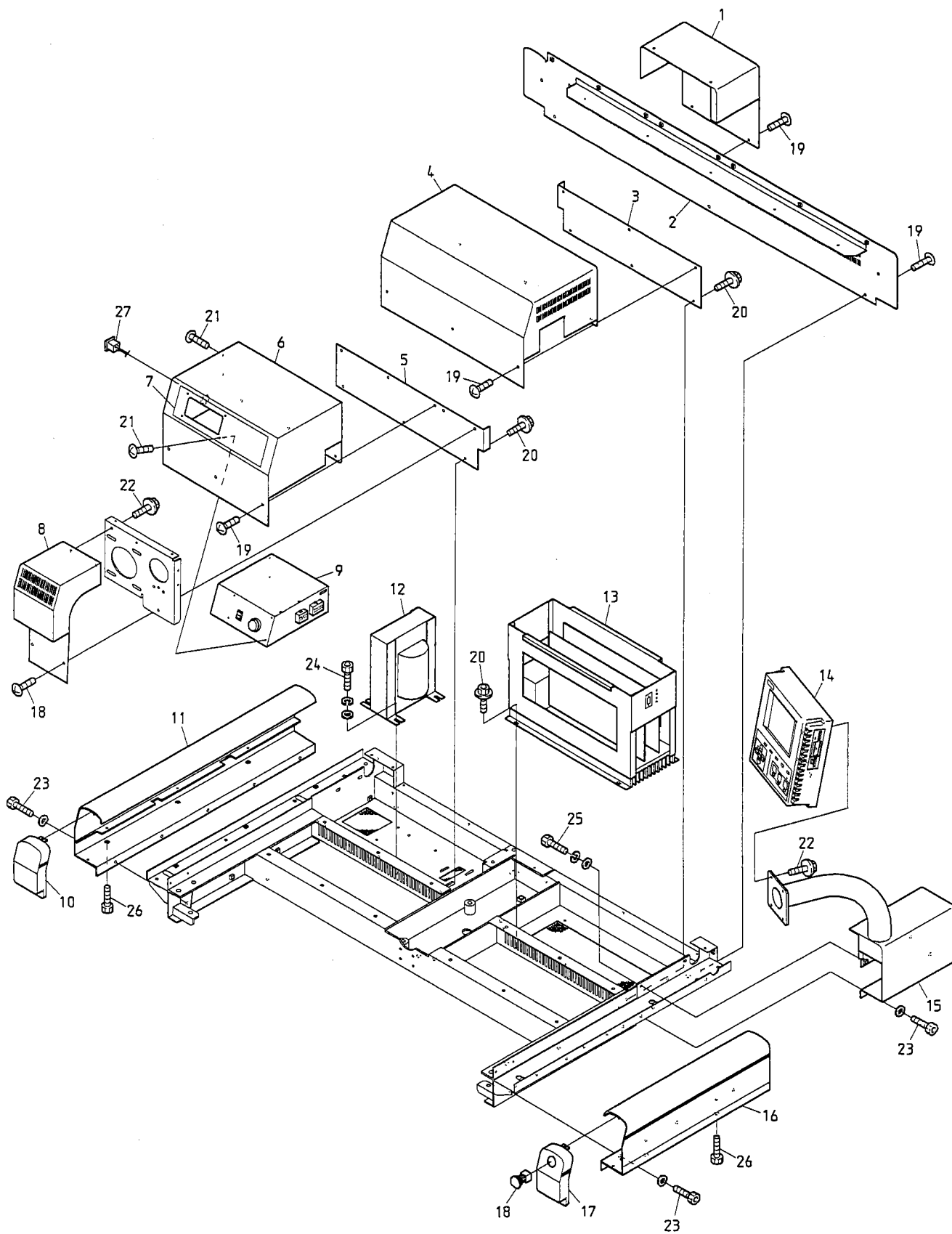

BENT-ZN

12 Accessories
付属品

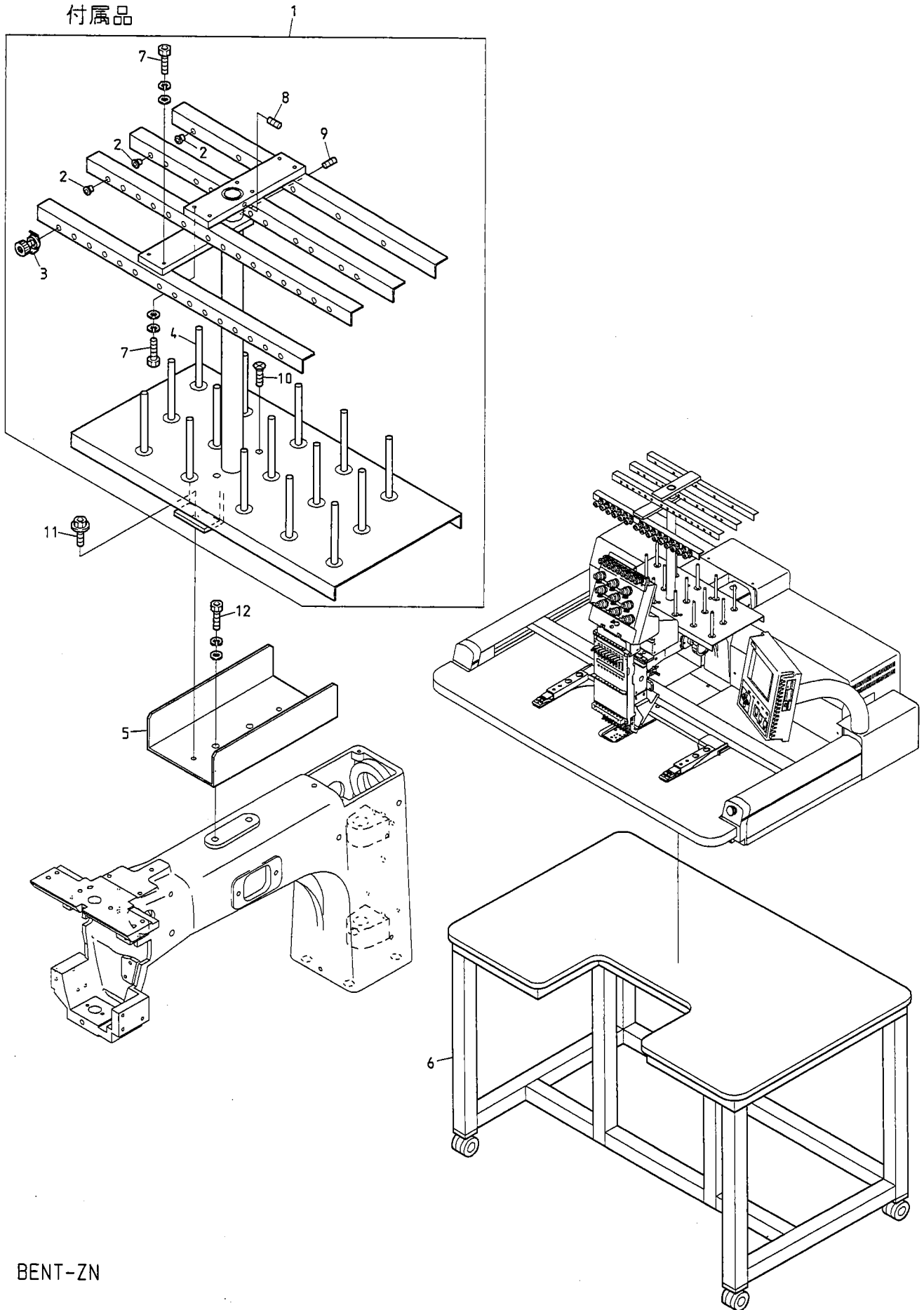

BENT-ZN



I N D E X

LIST No.	SECTION No.	ITEM	LIST No.	SECTION No.	ITEM
A 9 0 1 0 0 1 7	0 1 A	3	B M F 4 8 0 3 8 0	1 0 B	1 1
A 9 0 1 0 0 3 9	1 0 A	1 2	E A Y 0 3 9 A 1	1 1	1 4
A 9 0 1 0 0 6 3	0 7	1 6	E A Y 0 3 9 A 2	1 1	1 3
A 9 0 1 0 0 6 5	0 4 A	2 5	E A Y 0 3 9 A 3	1 1	1 2
A 9 0 1 0 1 0 6	1 0 A	1 6	E A Y 0 3 9 A 5	1 1	9
A 9 0 1 0 1 0 7	0 7	6	E B Y 0 1 1 1 0	0 6 B	9
A 9 0 1 1 1 0 3	1 0 A	2	E B Y 0 1 6 2 1	0 6 A	1 2
A 9 0 1 1 1 1 5	0 4 B	1 4	E B Y 0 1 6 2 5	0 6 A	3 2
A 9 0 1 1 1 2 3	1 0 A	4 3	E B Y 0 1 7 1 0	1 1	1 8
A 9 0 1 1 1 3 4	0 7	3 0	F N 0 7 0 0 1 1 S N Y	0 4 A	1 3
A 9 0 1 1 2 3 5	1 0 A	4	H B 2 3 0 2 7 0	0 3	1 3
A 9 0 1 1 2 3 6	1 0 A	1 9	H B 2 3 0 3 7 2	0 4 B	9
A 9 0 1 2 0 0 7	0 1 A	2 2	H B 2 3 0 3 8 3	0 4 B	5
A 9 0 1 2 0 0 7	0 2 B	9	H B 2 3 0 3 9 0	0 4 B	3
A 9 0 1 2 0 2 7	0 1 B	1 6	H B 2 3 0 4 0 1	0 4 B	2
A 9 0 1 2 0 5 1	0 5	1 6	H B 2 3 0 4 1 4	0 4 B	8
A 9 0 1 2 0 5 3	0 4 A	2 1	H B 2 3 0 4 2 0	0 4 B	7
A 9 0 1 2 0 7 7	0 8	1 2	H B 2 3 0 5 6 0	0 5	7
A 9 0 1 2 1 1 4	0 2 A	1 3	H B 2 3 0 5 8 0	0 5	9
A 9 0 1 2 1 2 7	0 2 D	1 9	H B 2 3 0 5 9 0	0 4 B	1
A 9 0 1 2 1 6 4	0 3	1 0	H B 2 3 0 6 5 0	0 3	2 4
A 9 0 1 2 1 9 0	0 4 B	4	H B 2 4 0 0 2 0	0 5	1 0
A 9 0 1 2 3 6 8	0 2 D	1 5	H B 2 4 0 0 3 0	0 5	1 1
A 9 0 1 2 4 0 6	1 0 A	1 5	H B 2 4 0 0 4 1	0 5	8
A 9 0 1 3 0 6 6	0 2 A	6	H B 2 4 0 0 8 0	0 5	1
A 9 0 1 4 0 5 1	0 5	1 5	H B 2 4 0 0 9 0	0 5	1 7
A 9 0 1 9 0 3 3	0 0	3	H B 2 4 0 1 1 0	0 5	1 3
A 9 0 2 0 1 8 1	0 8	1	H P 2 3 1 3 9 0	0 1 A	9
A 9 0 2 0 1 8 2	1 0 B	1	H P 2 4 1 4 8 0	1 2	3
A 9 0 2 0 1 8 3	1 0 A	2 2	H P 3 2 1 7 2 0	0 7	1
A 9 0 2 0 1 8 4	1 0 A	1 3	H T 2 3 0 0 4 1	0 4 A	3
A 9 0 5 2 0 0 5	0 2 A	1 4	H T 2 3 0 0 5 1	0 4 A	7
A 9 0 5 2 0 2 8	0 2 C	4	H T 2 3 0 0 9 0	0 3	6
A 9 0 5 2 0 3 0	1 0 A	8	H T 2 3 0 1 0 0	0 3	7
A 9 0 5 2 0 3 0	1 0 B	4	H T 2 3 0 1 3 0	0 4 A	1
A 9 0 5 2 0 3 1	1 0 A	9	H T 2 3 0 1 4 3	0 4 A	9
A 9 0 5 2 0 3 1	1 0 B	2 3	H T 2 3 0 1 5 1	0 4 A	2
A 9 0 5 6 0 0 8	0 2 B	1	H T 2 3 0 2 0 1	0 4 B	6
A 9 0 5 6 0 1 3	0 2 D	2 3	H T 2 3 0 2 2 0	0 5	4
A 9 0 5 6 0 1 8	0 2 C	1	H T 2 3 0 2 5 1	0 4 A	5
A 9 0 5 6 0 2 0	0 5	6	H T 2 3 0 2 6 3	0 4 A	6
A 9 0 6 8 0 3 2	0 6 A	3	H T 2 3 0 5 2 0	0 2 D	1 4
A 9 0 7 5 1 1 7	0 1 A	3 2	H T 2 3 0 6 2 0	0 5	5
B K K 4 6 0 0 6 2	1 0 B	1 0	H T 2 3 0 6 7 0	0 4 A	1 2
B M F 4 8 0 0 6 1	1 0 B	1 8	H T 2 3 0 8 1 0	0 4 A	4

I N D E X

L I S T No.	SECTION No.	ITEM	L I S T No.	SECTION No.	ITEM
HT 2 4 0 0 6 2	0 6 A	1 0	K C 2 7 1 0 4 1	0 2 B	5
HT 2 4 0 1 0 0	0 6 B	7	K C 2 7 1 1 2 0	0 2 A	1 2
HT 2 4 0 1 2 0	0 6 A	1	K C 2 7 1 9 4 0	0 2 B	4
HT 2 4 0 1 5 0	0 6 A	4	K C 2 7 1 9 6 0	0 2 B	3
HT 2 4 0 1 6 0	0 6 A	5	K C 5 1 0 2 4 0	0 8	4
HT 2 4 0 1 7 0	0 6 A	6	K F 2 2 0 1 3 0	0 1 A	7
HT 2 4 0 1 8 0	0 6 A	7	K F 2 2 0 2 3 0	0 1 B	1 0
HT 2 4 0 2 1 1	0 6 A	1 5	K F 2 2 0 2 7 1	0 1 B	4
HT 2 4 0 2 2 0	0 6 A	1 6	K F 2 2 0 2 9 0	0 1 B	1 1
HT 2 4 0 2 3 0	0 6 A	1 7	K F 2 2 0 4 1 0	0 1 B	8
HT 2 4 0 2 4 0	0 6 A	1 8	K F 2 2 0 4 4 0	0 1 B	7
HT 2 4 0 2 5 0	0 6 B	4	K F 2 2 0 4 6 0	0 1 A	1 4
HT 2 4 0 2 7 0	0 6 B	1 0	K F 2 2 0 4 7 0	0 1 B	1
HT 2 4 0 2 8 0	0 6 B	8	K F 2 2 0 4 8 0	0 1 B	1 3
HT 2 4 0 2 9 0	0 6 B	2	K F 2 2 0 7 5 0	0 1 B	9
HT 2 4 0 3 0 0	0 6 B	3	K F 2 3 0 2 4 0	0 4 A	2 7
HT 2 4 0 3 1 0	0 6 B	5	K F 2 3 0 4 2 0	0 1 A	2 0
HT 2 4 0 3 3 1	0 6 A	1 9	K F 2 3 0 5 0 0	0 3	8
HT 2 4 0 3 4 0	0 6 B	1	K F 2 3 0 5 8 2	0 2 D	6
HT 2 4 0 3 9 1	0 6 A	1 1	K F 2 3 0 9 1 0	0 4 A	1 0
HT 2 4 0 4 8 0	1 2	2	K F 2 3 0 9 2 0	0 4 A	1 6
HT 2 4 0 5 2 3	0 6 A	1 4	K F 2 5 0 2 2 0	0 2 D	5
HT 2 7 0 0 6 2	0 2 D	1 1	K F 2 5 0 2 3 1	0 2 D	3
HT 2 7 0 1 6 0	0 2 A	3	K F 2 5 0 2 4 1	0 2 D	4
HT 2 7 0 1 8 0	0 2 A	4	K F 2 5 0 2 5 0	0 2 D	2
HT 7 1 0 0 0 0	1 2	4	K F 7 3 0 5 0 0	1 0 B	2 4
KB 2 3 0 0 1 0	0 1 A	2 3	KL 2 2 0 0 0 0	0 1 A	1 2
KB 2 3 0 0 3 0	0 1 A	2 6	KL 2 2 0 0 1 0	0 1 A	1 7
KB 2 3 0 0 5 0	0 1 A	2 1	KL 2 2 0 0 2 0	0 1 A	1 9
KB 2 3 0 0 6 0	0 4 B	1 3	KL 2 2 0 0 3 0	0 1 A	1 1
KB 2 3 0 0 7 0	0 4 B	1 2	KL 2 2 0 0 4 0	0 1 A	4
KB 2 3 0 0 8 0	0 4 B	1 1	KL 2 2 0 0 5 0	0 1 A	1 6
KB 2 3 0 1 0 0	0 3	1 1	KL 2 2 0 0 6 0	0 1 B	2
KB 2 3 0 1 1 0	0 3	1 2	KL 2 2 0 0 7 0	0 1 B	1 2
KB 2 4 0 0 4 0	0 5	1 2	KL 2 2 0 0 8 0	0 1 A	8
K C 2 2 0 2 1 0	0 1 B	1 9	KL 2 2 0 0 9 0	0 1 A	2
K C 2 2 0 6 4 2	0 2 B	1 0	KL 2 2 0 1 2 0	0 1 B	2 0
K C 2 5 0 4 7 1	0 1 B	1 7	KL 2 2 0 1 3 0	0 1 A	1 0
K C 2 5 0 4 8 2	0 1 B	1 8	KL 2 2 0 1 4 0	0 1 A	1 5
K C 2 5 1 3 3 0	0 1 A	1 3	KL 2 2 0 1 4 0	0 1 B	3
K C 2 7 0 1 0 1	0 2 D	2 4	KL 2 2 0 1 5 0	0 1 A	6
K C 2 7 0 9 7 0	0 2 A	8	KL 2 5 0 0 5 1	0 1 A	1
K C 2 7 1 0 0 2	0 2 B	8	KL 2 7 0 0 8 1	0 2 C	2
K C 2 7 1 0 2 1	0 2 B	7	KL 2 7 0 0 9 1	0 2 C	8
K C 2 7 1 0 3 1	0 2 B	6	KL 2 7 0 1 0 1	0 2 C	9

I N D E X

LIST No.	SECTION No.	ITEM	LIST No.	SECTION No.	ITEM
KL 2 7 0 1 1 0	0 2 C	7	KX 2 5 0 0 1 0	0 1 B	1 5
KL 2 7 0 1 2 0	0 2 C	1 0	KX 2 5 0 0 3 0	0 3	2 9
KL 2 7 0 1 3 0	0 2 C	1 1	KX 2 5 0 0 4 1	0 4 C	4
KL 2 7 0 2 6 0	0 2 C	3	KX 2 5 0 0 5 1	0 4 C	2
KL 2 7 0 4 5 0	0 2 C	6	KX 2 5 0 0 7 0	0 4 C	3
KN 2 7 0 9 5 2	0 2 A	5	KX 2 5 0 0 8 0	0 1 B	2 3
KN 2 7 0 9 6 1	0 2 A	2	KX 2 5 0 0 8 0	0 2 A	7
KN 2 7 2 4 0 0	0 2 B	2	KX 2 5 0 1 0 0	0 3	2 8
KN 2 7 2 4 0 0	0 2 C	5	KX 2 5 0 1 1 0	0 6 A	3 3
KN 5 4 0 5 1 0	0 6 B	6	KX 2 7 0 0 1 0	0 2 A	9
KR 3 3 0 1 9 0	0 7	1 2	KX 2 7 0 0 2 1	0 2 A	1
KT 2 3 0 0 3 1	0 3	5	KX 2 7 0 0 3 0	0 2 A	1 1
KT 2 3 0 0 5 1	0 3	9	KX 2 7 0 0 5 0	0 2 C	1 2
KX 2 3 0 0 1 0	0 4 A	1 8	KX 2 7 0 0 6 0	0 2 C	1 5
KX 2 3 0 0 2 2	0 4 A	2 0	KX 2 7 0 0 7 0	0 2 C	1 4
KX 2 3 0 0 3 0	0 4 A	2 3	KX 2 7 0 0 8 0	0 2 D	1 2
KX 2 3 0 0 4 0	0 4 A	1 7	KX 2 7 0 0 9 0	0 2 D	9
KX 2 3 0 0 5 0	0 4 A	2 4	KX 2 7 0 1 0 0	0 2 D	8
KX 2 3 0 0 6 0	0 4 A	1 9	KX 2 7 0 1 1 0	0 2 D	7
KX 2 3 0 0 7 0	0 3	4	KX 2 7 0 1 2 0	0 2 D	1 0
KX 2 3 0 0 8 0	0 4 A	2 6	KX 2 7 0 2 2 0	0 2 C	1 6
KX 2 3 0 0 9 0	0 3	1	KX 2 7 0 2 3 0	0 2 D	1
KX 2 3 0 1 0 0	0 5	3	KX 2 7 0 2 5 1	0 4 C	1
KX 2 3 0 1 1 0	0 3	1 8	KX 2 7 0 2 8 0	0 2 A	1 0
KX 2 3 0 1 2 0	0 3	1 7	KX 2 7 0 2 9 0	0 2 D	1 8
KX 2 3 0 1 3 0	0 3	1 4	KX 2 7 0 3 0 0	0 2 D	2 2
KX 2 3 0 1 4 0	0 3	1 5	KX 2 7 0 3 1 0	0 2 D	2 0
KX 2 3 0 1 5 1	0 3	1 6	KX 2 7 0 3 2 0	0 2 D	1 7
KX 2 3 0 1 6 2	0 3	2	KX 2 7 0 3 3 0	0 2 D	2 5
KX 2 3 0 1 8 0	0 4 A	1 5	KX 2 7 0 3 4 0	0 2 D	1 3
KX 2 3 0 1 9 0	0 4 A	2 2	KX 2 7 0 3 5 0	0 2 D	2 1
KX 2 3 0 2 0 0	0 3	1 9	KX 2 7 0 3 6 0	0 2 D	1 6
KX 2 3 0 2 1 0	0 4 B	1 0	KX 2 7 0 3 7 0	0 2 C	1 3
KX 2 3 0 2 5 0	0 4 A	8	KX 2 7 0 3 8 0	0 2 A	3 3
KX 2 3 0 2 8 0	0 4 A	1 4	KX 3 3 0 1 2 0	0 7	7
KX 2 3 0 3 0 0	0 4 A	4 0	KX 3 3 0 1 6 0	0 7	1 5
KX 2 3 0 3 1 0	0 3	3 0	KX 3 3 0 2 8 0	0 7	1 8
KX 2 4 0 0 0 0	0 6 A	2 1	KX 3 3 0 3 2 0	0 6 A	2
KX 2 4 0 0 1 0	0 6 A	2 0	KX 3 3 0 3 3 0	0 6 A	1 3
KX 2 4 0 0 2 0	0 3	2 0	KX 7 9 0 0 0 0	0 3	3 2
KX 2 4 0 0 3 1	0 6 A	9	MB 2 9 5 2 5 0	0 2 A	1 7
KX 2 4 0 0 4 0	0 5	2	MB 2 9 5 2 6 0	0 2 A	2 0
KX 2 4 0 0 5 0	0 5	1 4	MB 2 9 5 2 7 0	0 2 A	1 9
KX 2 4 0 1 5 0	0 6 A	3 5	MB 2 9 5 2 9 0	0 2 A	1 8
KX 2 5 0 0 0 0	0 1 B	5	MF 1 1 0 0 1 1	1 2	6

I N D E X

LIST No.	SECTION No.	ITEM	LIST No.	SECTION No.	ITEM
MF 1 1 1 0 0 0	0 0	8	MF 4 8 0 0 0 0	1 0 B	8
MF 1 2 1 0 0 0	0 0	1	MF 4 8 0 0 1 0	1 0 B	9
MF 1 2 1 0 1 0	0 0	5	MF 4 8 0 0 2 1	1 0 B	1 9
MF 1 4 0 0 5 0	0 0	1 0	MF 4 8 0 0 3 0	1 0 B	2 0
MF 1 4 0 0 6 0	0 0	7	MF 4 8 0 0 4 0	1 0 B	1 6
MF 1 4 0 0 7 0	0 0	6	MF 4 8 0 0 8 0	1 0 B	1 2
MF 1 4 1 0 1 0	0 0	2	MF 4 8 0 0 9 0	1 0 B	5
MF 1 4 1 0 3 0	0 0	4	MF 4 8 0 1 3 0	1 0 A	2 1
MF 1 4 1 0 4 0	0 0	9	MF 4 8 0 1 4 0	1 0 A	2 6
MF 2 1 0 0 5 0	0 2 A	2 2	MF 4 8 0 1 5 0	1 0 A	1
MF 2 1 0 0 6 0	0 2 A	2 1	MF 4 8 0 1 6 1	1 0 A	3
MF 2 1 0 0 7 0	0 2 A	1 6	MF 4 8 0 1 9 0	1 0 A	6
MF 2 1 0 0 8 0	0 2 A	1 5	MF 4 8 0 3 2 0	1 0 B	6
MF 2 1 0 1 1 0	0 1 B	6	MF 4 8 0 3 3 0	1 0 A	1 0
MF 2 1 0 1 3 0	0 1 A	2 4	MF 4 8 0 3 3 0	1 0 B	2 2
MF 2 2 0 0 0 0	0 1 A	3 1	MF 4 8 0 3 4 0	1 0 A	7
MF 2 3 0 0 0 0	0 4 A	1 1	MF 4 8 0 3 4 0	1 0 B	3
MF 2 5 0 0 0 0	1 1	4	MF 4 8 0 3 5 0	1 0 B	7
MF 2 5 0 0 1 1	1 1	6	MF 4 8 0 3 6 0	1 0 B	2
MF 2 5 0 0 2 0	1 1	8	MF 4 8 0 3 7 0	1 0 B	1 5
MF 2 5 0 0 3 1	1 1	1 5	MF 4 8 0 4 0 0	1 0 A	2 4
MF 2 5 0 0 4 0	1 1	2	MF 4 8 0 4 0 0	1 0 B	1 4
MF 2 5 0 0 5 0	1 1	1	MF 4 8 0 4 2 0	1 0 B	1 7
MF 2 5 0 0 6 0	1 1	3	MF 4 8 0 4 5 0	1 0 B	3 1
MF 2 5 0 0 7 0	1 1	5	MF 4 8 0 5 0 0	1 0 B	2 1
MF 2 5 0 0 8 0	0 7	1 4	MF 4 8 1 1 2 0	1 0 B	1 3
MF 2 5 0 0 9 0	1 1	1 7	MF 4 8 1 1 7 0	1 0 A	1 8
MF 2 5 0 1 2 0	1 1	1 0	MF 4 8 1 1 8 0	1 0 A	1 1
MF 2 5 0 1 3 1	0 0	1 1	MF 4 8 1 2 1 0	1 0 A	5
MF 2 5 0 1 4 0	0 4 C	5	MF 4 8 1 2 2 0	1 0 A	2 5
MF 2 5 1 1 0 0	1 1	1 1	MF 4 8 1 2 3 0	1 0 A	2 0
MF 2 5 1 1 1 0	1 1	1 6	MF 4 8 1 2 4 0	1 0 A	1 4
MF 3 1 0 0 0 0	0 8	1 0	MF 4 8 1 2 9 0	1 0 A	2 3
MF 3 1 0 0 1 0	0 8	2	MF 4 8 1 3 0 0	1 0 A	1 7
MF 3 1 0 0 2 0	0 8	9	MF 5 1 0 0 0 0	0 8	6
MF 3 1 0 0 3 0	0 8	8	MF 5 1 0 0 1 0	0 7	3
MF 3 1 0 0 4 0	0 8	5	MF 5 1 0 0 2 0	0 2 A	2 3
MF 3 2 0 0 0 0	0 7	4	MF 5 1 0 0 2 0	0 7	1 1
MF 3 2 0 0 1 0	0 7	1 0	MF 5 1 0 0 3 0	0 8	7
MF 3 3 0 0 0 0	0 7	8	MF 5 1 0 0 4 0	1 1	2 7
MF 3 3 0 0 1 0	0 7	2	MF 7 1 0 0 0 1	1 2	1
MF 3 3 0 0 2 0	0 7	1 7	MF 7 1 0 0 1 1	1 2	5
MF 3 3 0 0 3 0	0 7	9	MF 7 9 0 0 3 0	1 1	7
MF 3 3 0 0 4 0	0 7	5	MY 2 9 4 2 8 0	0 8	3
MF 3 3 0 0 5 0	0 7	1 3	MY 2 9 4 4 2 0	0 8	1 6

I N D E X

LIST No.	SECTION No.	ITEM	LIST No.	SECTION No.	ITEM
MY 2 9 4 4 3 0	0 8	1 3			
MY 2 9 4 4 4 0	0 1 A	1 8			
MY 2 9 4 4 5 0	0 8	1 1			
MY 2 9 4 4 6 0	0 8	1 5			
MY 2 9 4 4 7 0	0 8	1 4			
MY 2 9 4 6 0 0	0 1 A	5			

