

PARTS IDENTIFICATION

7. PARTS IDENTIFICATION DRAWINGS
 7.1. M700XL MACHINE LESS SEWING HEAD
 7.1.1. FRAME ASSEMBLY

ASSEMBLY NAME: XL Frame Assembly ASSEMBLY FIG. NO.: 7.1
 7.2

<u>REF.</u>	<u>QTY.</u>	<u>PART NO.</u>	<u>DESCRIPTION</u>
01	1	P620000	M700XL Table Assembly
02	1	P530105	Control Logic Card
03	1	P530110	CPU3 Card Assembly
04	1	P530115	D-Ram Card Assembly
05	1	P530720	CPU-CLC Cable
06	1	P530817	CPU Power Supply Fuse F4; 1A, 250V
07	1	P530825	Power Control Fuse F5; 8A, 250V
08	1	P530818	DC Drive Fuse F6; 5A, 250V
09	1	P520033	Card Retainer
10	1	P620004	Left Front Panel - M700XL
11	1	P620005	Right Front Panel - M700XL
12	2	P620008	Side Panel - M700XL
13	1	P620007	Right Rear Panel - M700XL
14	1	P620006	Left Rear Panel - M700XL
15	12	P520083	Screw #6x1/2" Lg., Type AB Phillips Decorative Head
16	8	P840203	Screw, #8-32 x 1/2" Lg. Type F Hex Head
17	8	P620011	Tinnerman Clip for # 6 Type AB Screw
18	1	P530823	Main Power Fuse F7; 10A, 250V
19	1	P840188	Screw #6-32x1/2" Lg. Slotted Pan Head
20	1	P614000	M700XL Sewing Head Assembly
21	2	P514003	Head Hinge Pin
22	1	P820044	V-Belt, 44"
23	8	P840148	Screw, #6-32x 3/8" Lg. Phillips Flt Head
24	2	P520024	Head Hinge Plate
25	2	P840915	Rubber Hinge Insert (Grommet Z-399)
26	2	P620013	Die Cut Corner Pad
27	1	P620300	Belt Guard/Bobbin Winder Assembly
28	1	P220501	Template Holder Thumbscrew
29	3	P840305	Screw, Wood #7x3/4" Lg. Slotted Rnd Hd.
30	1	P840513	#6 Washer, Nylon
31	1	P840415	Screw, #6-32x1/4" Lg. Slotted Pan Head
32	1	P520327	Guard Stop, Bobbin Winder
33	1	B16011	Anti-Static Mat

Fig. 7-1: Frame Assembly Drawing - Front

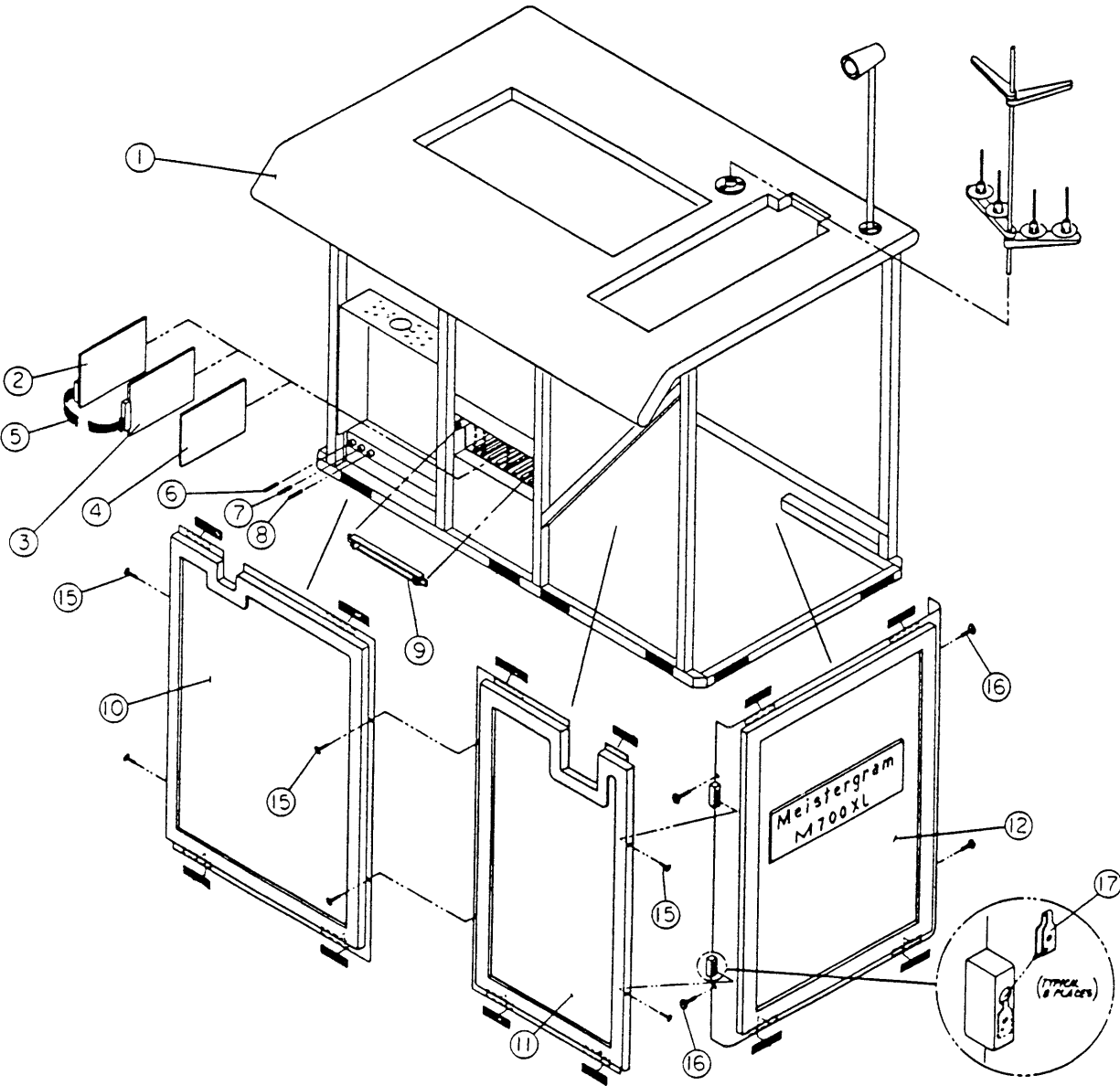
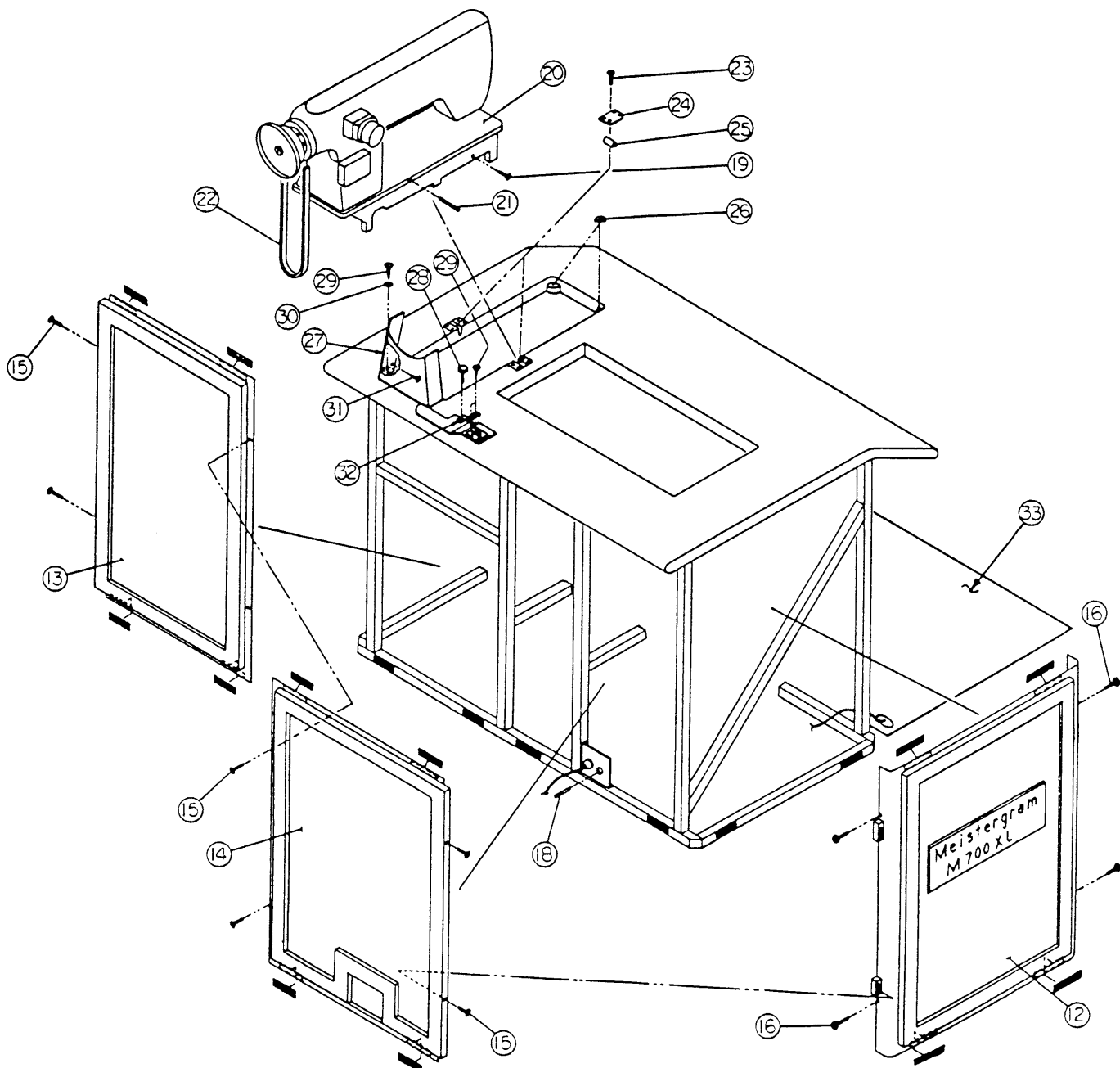

Fig. 7-2: Frame Assembly Drawing - Rear



7.1.2. Table Top Assembly

ASSEMBLY NAME: Table Top Assembly ASSEMBLY FIG. NO.: 7.3
7.4
7.5

<u>REF.</u>	<u>QTY.</u>	<u>PART NO.</u>	<u>DESCRIPTION</u>
01	1		Table Top Assembly, M700XL
02	1	P620010	Pantograph Cover Assembly with Hinges
03	4	P840313	Screw, Wood #10x3/4" Lg., Round Hd. Phillips
04	1	P520030	Thread Stand, 4 Cone
05	1	P530100	Control Console Assembly
06	1	P630108	Control Console Pedestal
07	1	P620028	Control Support Bracket, Right
08	1	P620027	Control Support Bracket, Left
09	2	P840795	Threaded Insert, #6-32
10	2	P520081	Screw, #6-32x5/8" Lg., Decorative Head
11	2	P620103	Thumb Screw, #10-32 x 1" Lg., 3/4" Dia. Head
12	2	P840530	#10 Flat Washer
13	2	P840572	#10 Lock Washer, Split
14	2	P840440	Screw, Machine, #10-32x2" Lg., Slotted Pan Hd
15	2	P840304	Screw, Wood #6x3/4" Lg., Slotted Pan Head
16	1	P620500	Hoop Arm Assembly, M700XL
17	1	P520501	Hoop Arm Base
18	2	P840561	5/16" Flat Washer
19	2	P840582	5/16" Lock Washer, Split
20	2	P840601	Bolt, 5/16"-18x3/4" Lg., Hex Head

Fig. 7-3: Control Console Installation

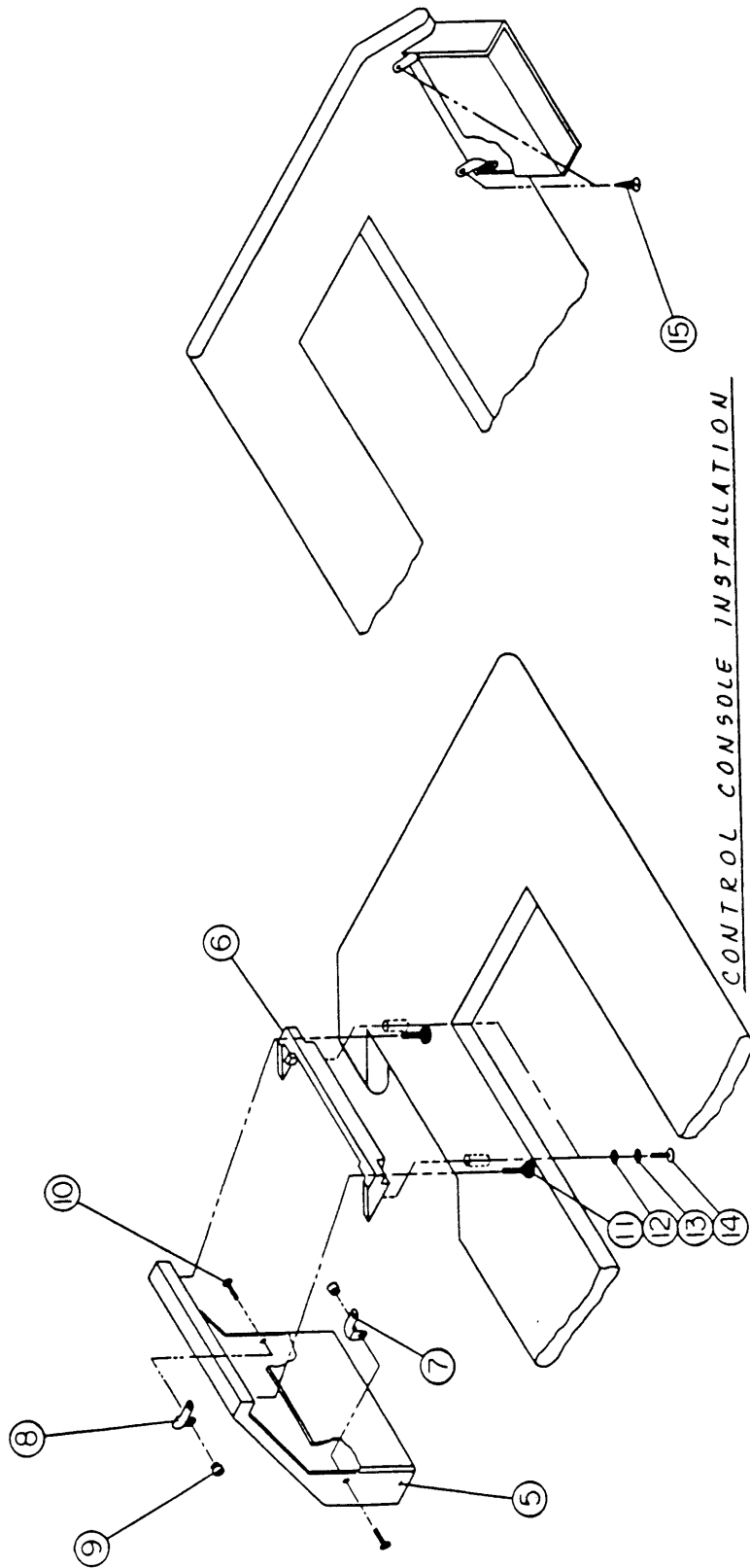

Fig. 7-4: Pantograph Cover & Thread Stand Installation

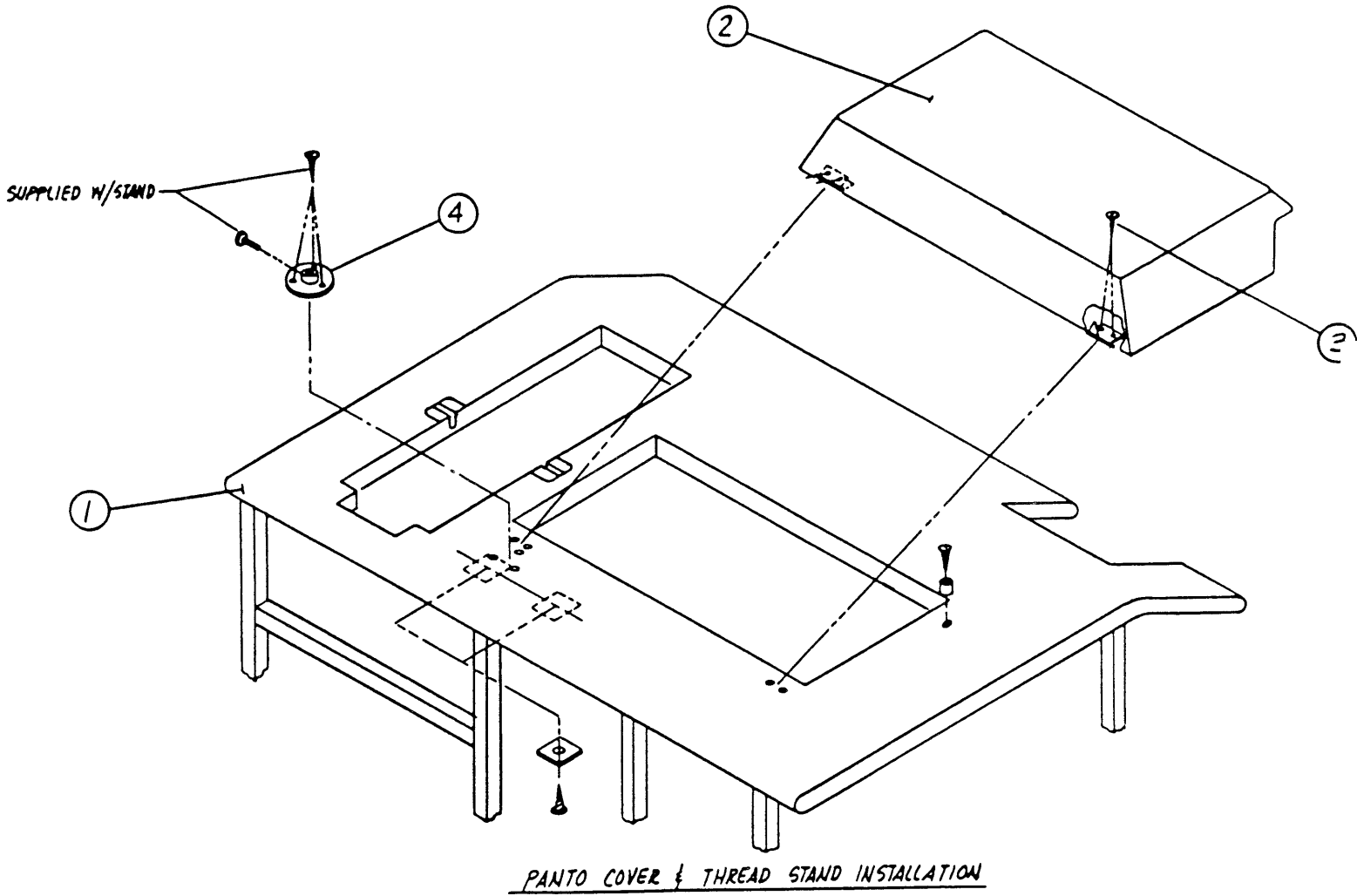
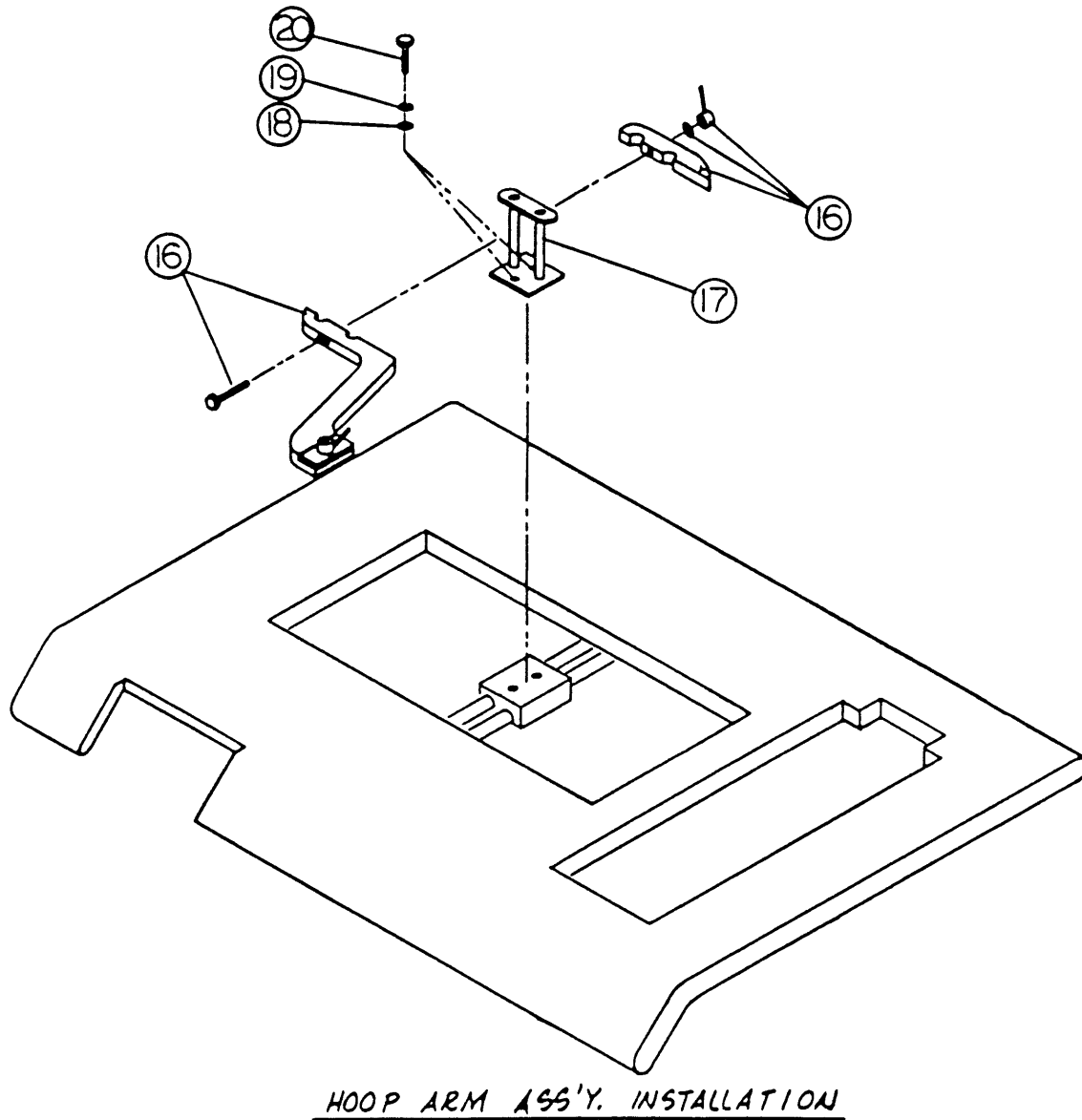

Fig. 7-5: Hoop Arm Assembly Installation



7.1.3. XL Sewing Head Assembly

ASSEMBLY NAME: Sewing Head Assy. ASSEMBLY FIG. NO.: 7.6
7.7
7.8
7.9
7.10

<u>REF.</u>	<u>QTY.</u>	<u>PART NO.</u>	<u>DESCRIPTION</u>
01	1	P413001	M700XL Sewing Head Assembly
02	1	P413022	Cover, Stitch Width Motor
03	1	P614038	Cover, Head Interface Card
04	1	P530408	Head Interface Card
05	2	P840916	Rubber Grommet, 2-633
06	2	P840410	Screw, #6-32 x 3/8" Lg. Slotted Pan Head
07	2	P840511	#6 Lockwasher, Internal Tooth
08	2	P614003	Standoff, #6-32 x 3/4" Lg., Male-Female Hex
09	2	P413035	Standoff, #6-32 x 1/4" Lg., Male-Female Hex
10	1	P413210	Thread Break Sensor Assembly
11	1	P413385	Screw, #10650
12	1	P614010	Tension Release Solenoid Assembly
13	1	P312027	Ty-Rap
14	1	P840122	Screw, #8-32 x 1/2" Lg. Slotted Flat Head
15	2	P840730	#8-32 Hex Nut
16	1	P840523	#8 Lockwasher, Split
17	1	P614040	PT/NPS Pick-Up Assembly
18	1	P614030	PT/NPS Sender Assembly
19	1	P614050	Stitch Width Motor Assembly
20	2	P413004	Support Post, 2" Lg.
21	2	P413003	Support Post, 1 3/4" Lg.
22	1	P312013	Coupling, Stitch Width Motor
23	1	P413017	Collar
24	1	P840725	#6-32 Hex Nut
25	1	P840189	Screw, Mach. #6-32 x 3/4" Lg. Slotted Pan Hd
26	1	P413018	Magnet
27	1	P614052	Bracket, Stitch Width Limit Sensor Mounting
28	1	P840401	Screw, #4-40 x 1/8" Lg. Slotted Pan Head
29	1	P614025	Stitch Width Limit Sensor Assembly

Fig. 7-6: Wire Routing and Head Interface Card Wiring

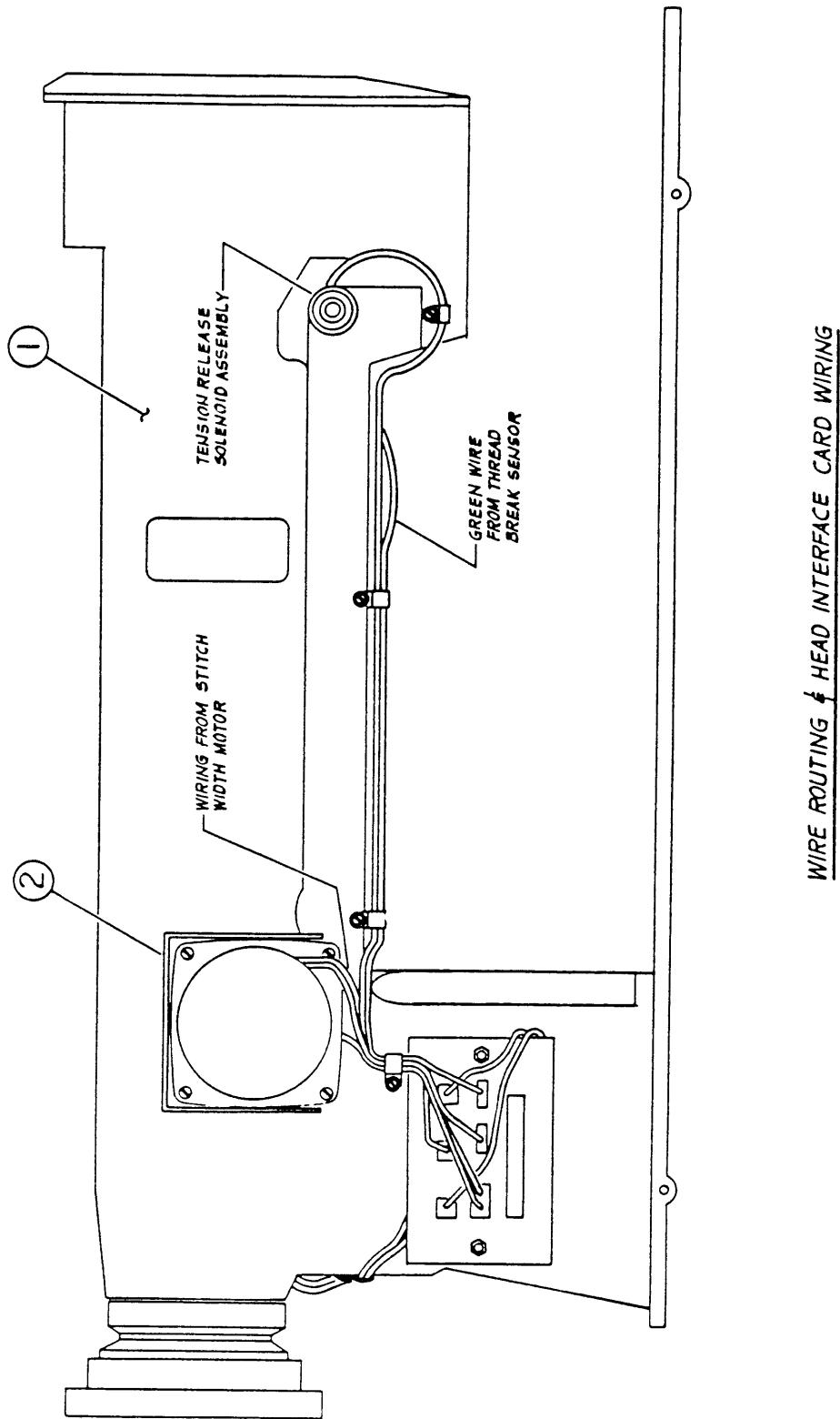
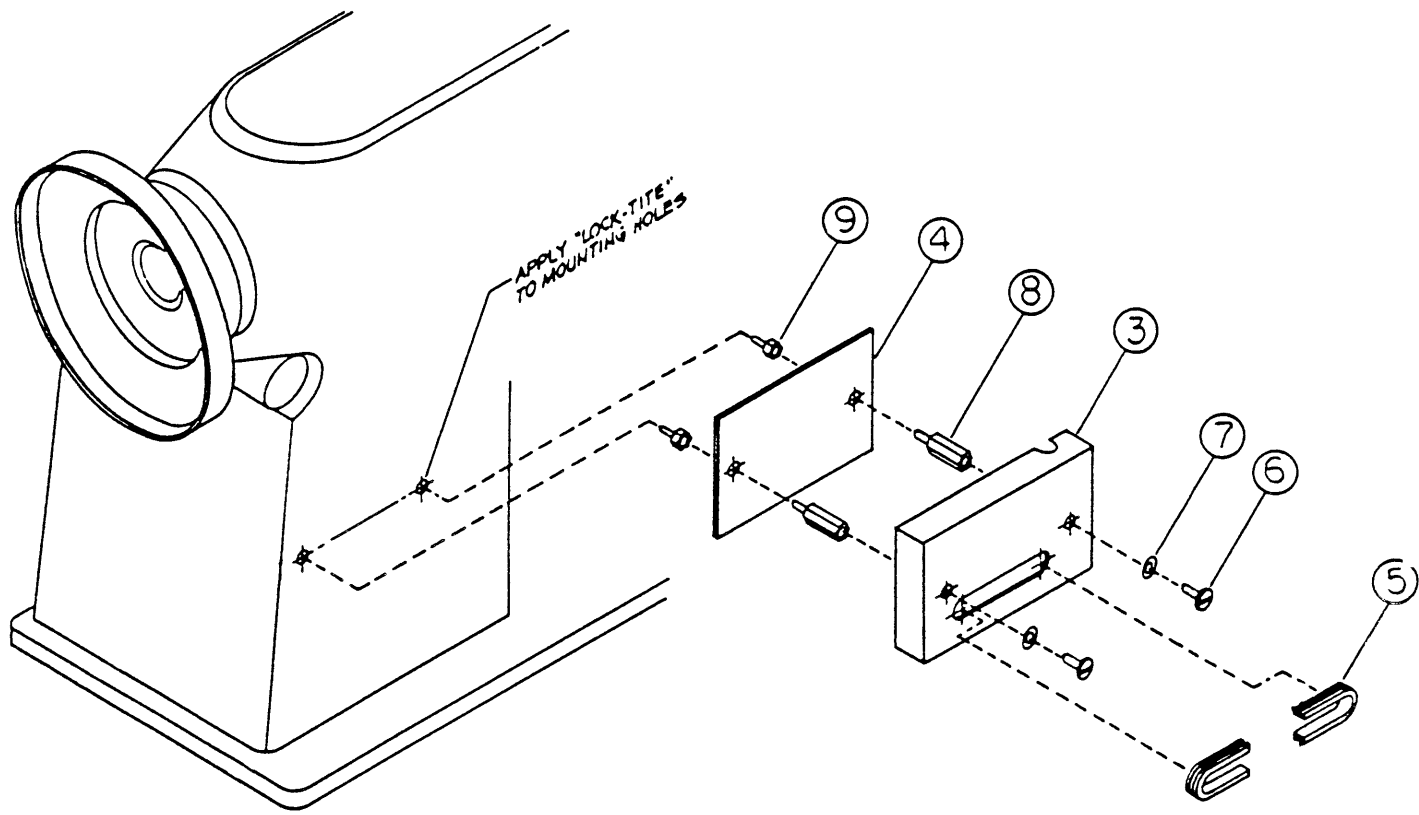
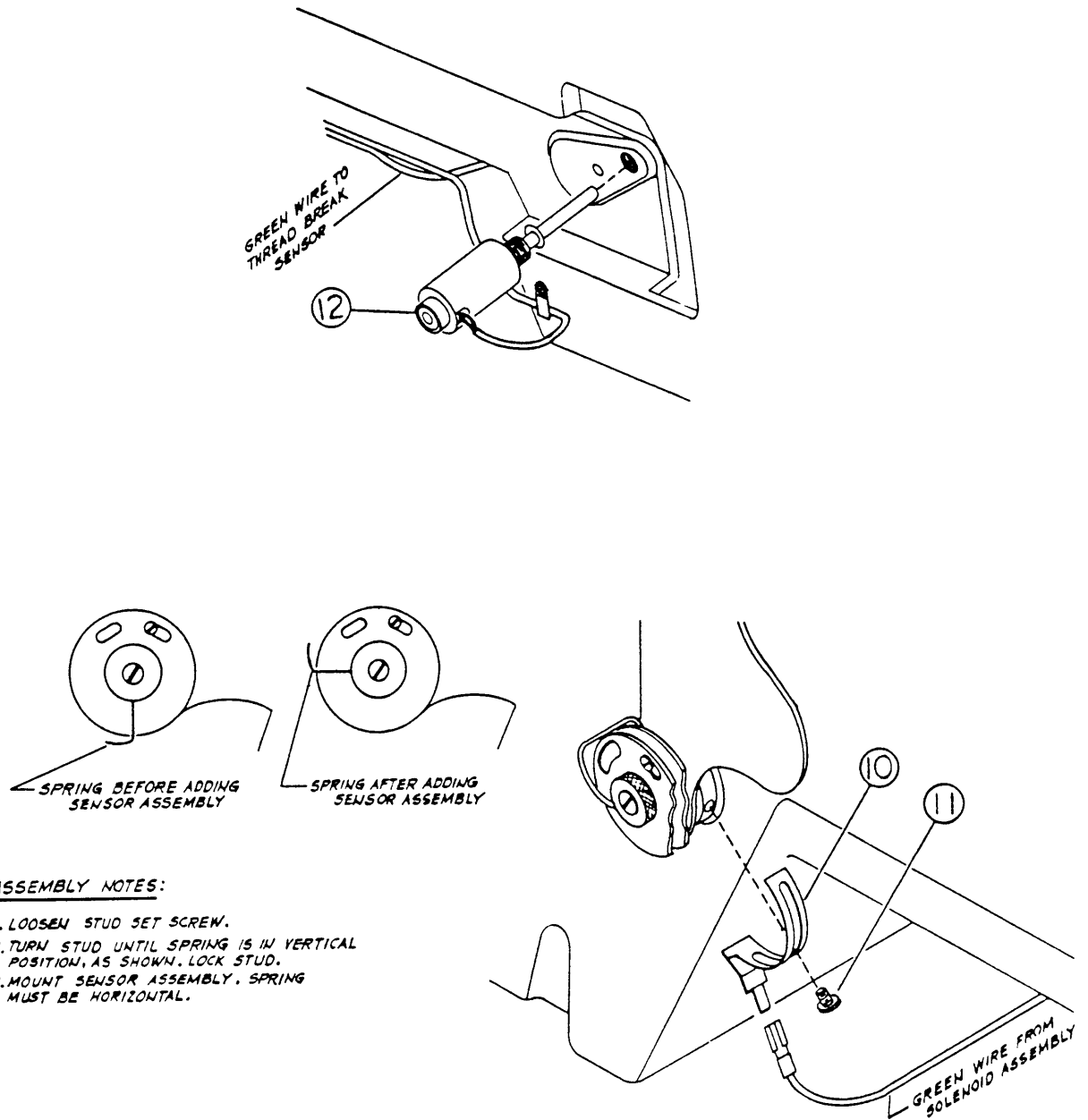

Fig. 7-7: Head Interface Card Assembly



HEAD INTERFACE CARD ASSEMBLY

Fig. 7-8: Mounting - Thread Break Sensor Assembly



ASSEMBLY NOTES:

1. LOOSEN STUD SET SCREW.
2. TURN STUD UNTIL SPRING IS IN VERTICAL POSITION, AS SHOWN. LOCK STUD.
3. MOUNT SENSOR ASSEMBLY. SPRING MUST BE HORIZONTAL.

MOUNTING - THREAD BREAK SENSOR ASSEMBLY

Fig. 7-9: PT/NPS Installation

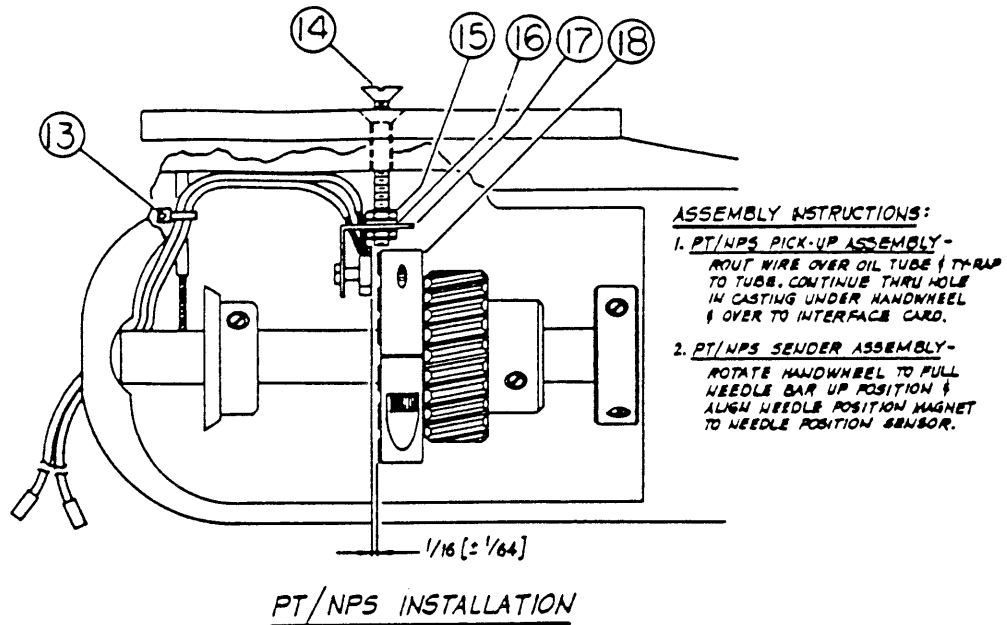
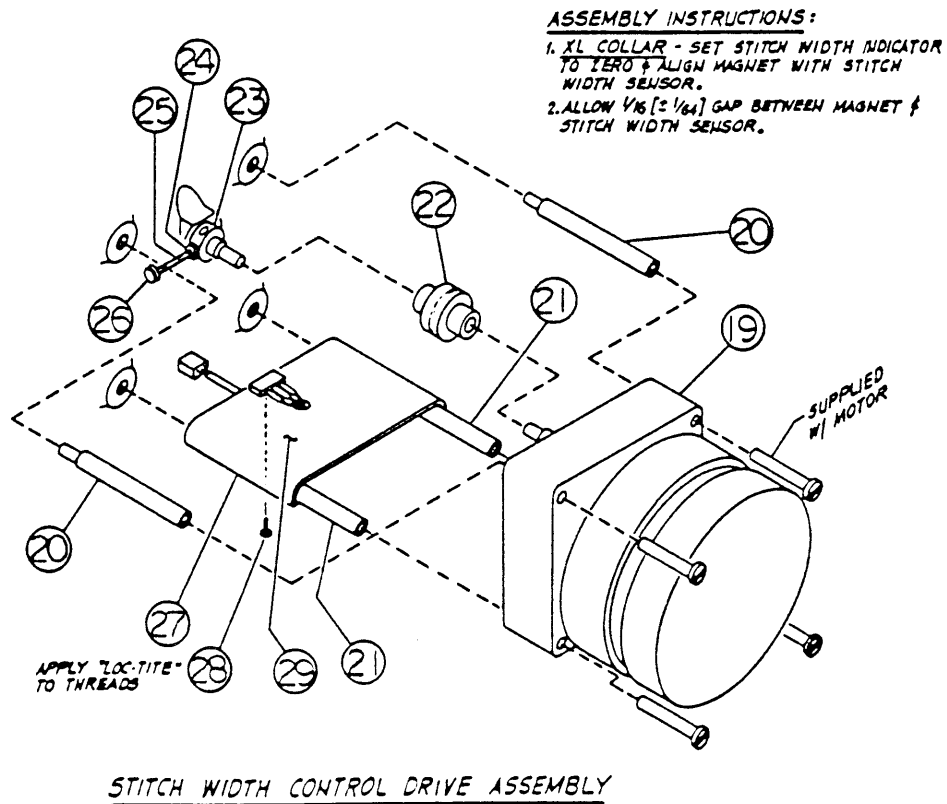

Fig. 7-10: Stitch Width Control Drive Assembly



7.1.4. XL Power Transformer Assembly

ASSEMBLY NAME: XL Power
Transformer Assy

ASSEMBLY FIG NO.: 7.11

REF.	QTY.	PART NO.	DESCRIPTION
01	1	P820033	Strain Relief Connector
02	1	P520105	Power Cord
03	1	P335167	Fuse Holder
04	2	P840740	#10-32 Hex Nut
05	1	P530500	Transformer Assembly
06	1	P840572	#10 Lockwasher, Split
07	2	P530519	Marker, Terminal Strip
08	2	P520107	Self-Clinch Stud, #6-32 x 7/8"
09	4	P840511	#6 Lockwasher, Internal Tooth
10	2	P520103	Standoff, #6-32 x 3/8" Hex Internal Thread
11	2	P840720	#6-32 Hex Nut
12	2	P840201	Screw, #6-32 x 5/8" Lg. Type "F" Hex Head
13	1	J840440	Screw, #10-32 x 2" Lg. Slotted Pan Head
14	4	P840197	Screw, 1/4-20 x 1/2" Lg. Type "F" Hex Head
15	1	P840576	#10 Lockwasher, Internal Tooth
16	1	P840770	1/2" Lock Nut

Fig. 7-11: Frame - Lower Left Corner

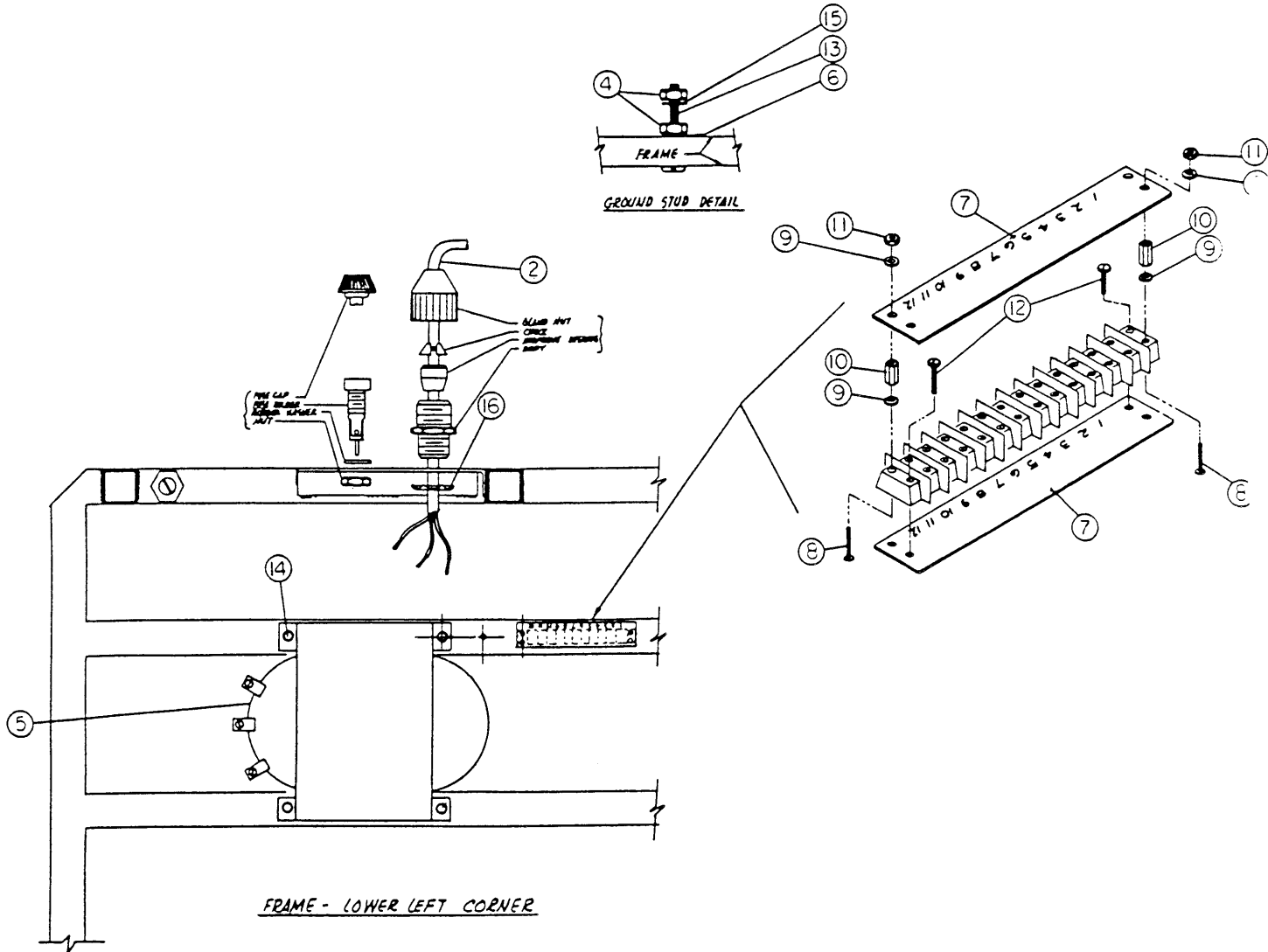

7.1.5. XL Frame Assembly - Front View

ASSEMBLY NAME: XL Frame Assy.

ASSEMBLY FIG. NO.: 7.12
7.13
7.14

REF.	QTY.	PART NO.	DESCRIPTION
01	2	P520068	Leveling Foot
02	1	P530412	Diagnostic Circuit Board
03	1	P530025	Card Cage Assembly
04	3	P840189	Screw, Mach., #6-32 x 3/4" Lg. Slotted Pan Hd
05	3	P840509	#6 Lockwasher, Split
06	3	P840720	#6-32 Hex Nut
07	3	P840510	#6 Flat Washer
08	4	P840417	Screw, Mach., #8-32 x 3/16" Lg. Slotted Pan Head

Fig. 7-12: Power Control Cover, Diagnostic Board & Leveling Installation

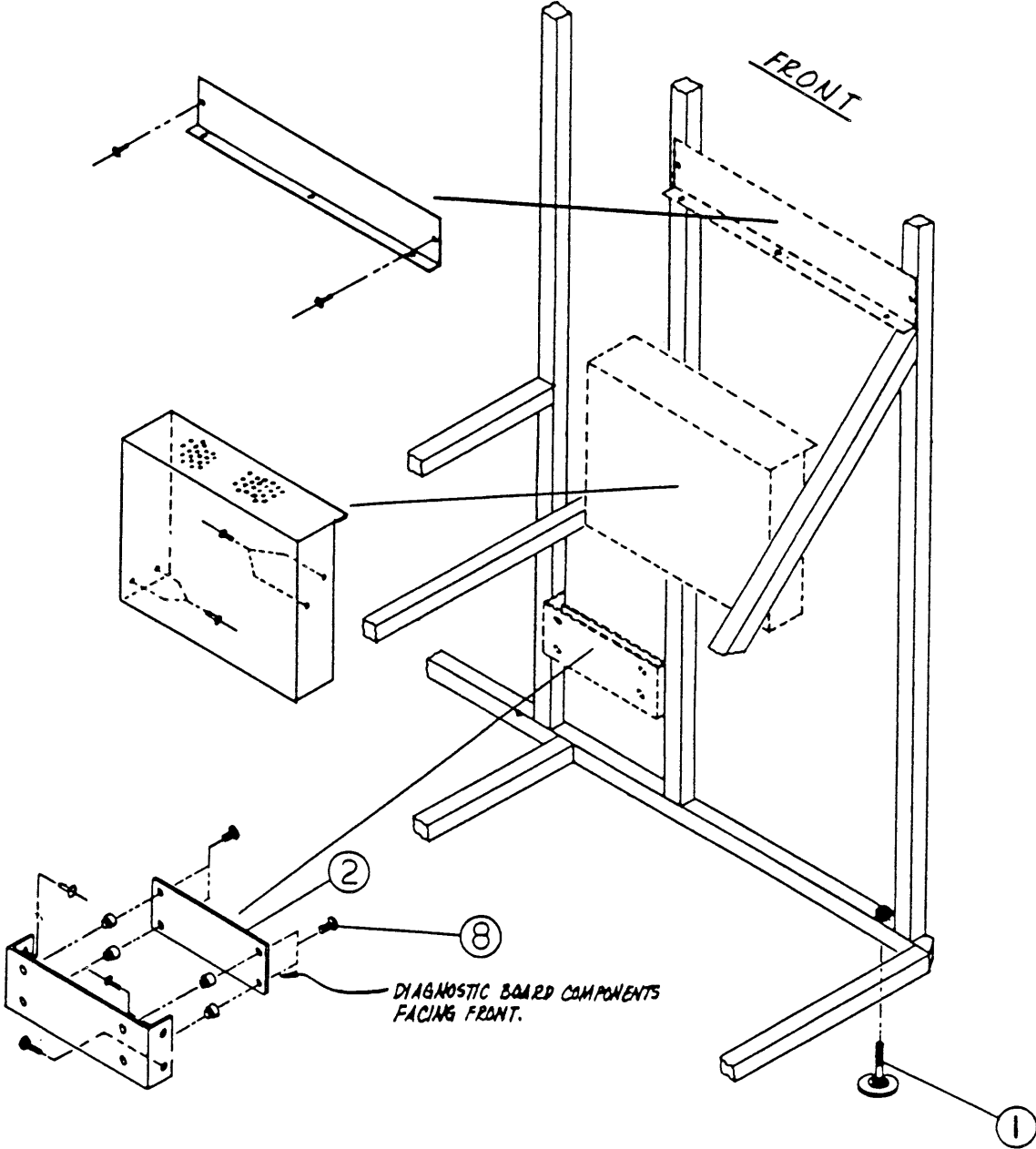

POWER CONTROL COVER, DIAGNOSTIC BOARD & LEVELING FEET INSTALLATION

Fig. 7-13: Card Cage & Decal Installation

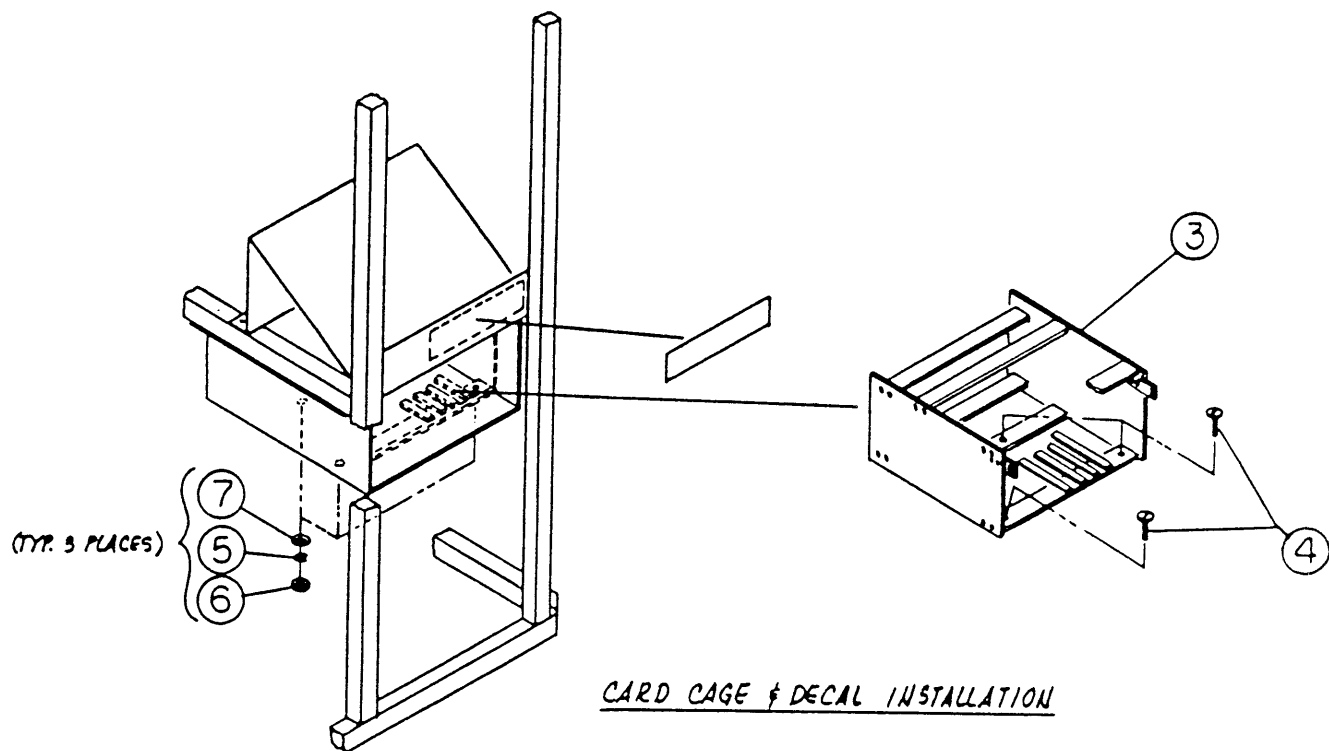
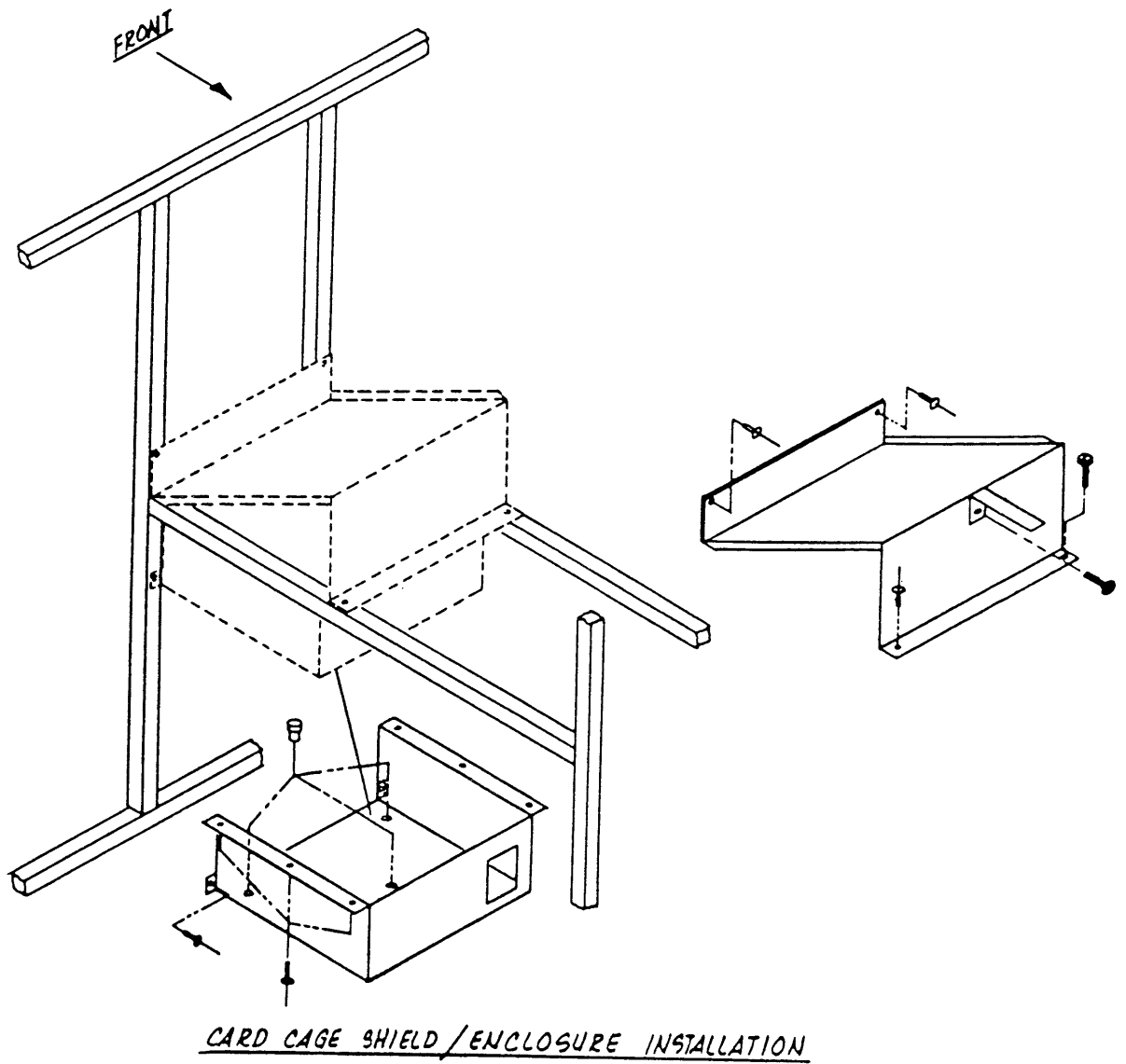

Fig. 7-14: Card Cage Shield/Enclosure Installation



7.1.6. XL Pantograph Assembly

ASSEMBLY NAME: XL Pantograph Assy

ASSEMBLY FIG. NO.: 7.15
7.16
7.17
7.18

REF.	QTY.	PART NO.	DESCRIPTION
01	1	P620400	Pantograph Assembly, M700XL
02	4	P840142	Screw, Mach. 1/4-20 x 1 3/4" Lg. Slotted Flat Head
03	4	P520509	Neoprene Well Nut, 1/4-20 Thread
04	4	P520402	Rubber Grommet, Z-148
05	4	P520406	T-Nut, 1/4-20 x 7/16" Plain Slab Base
06	1	P520072	Head Locking Screw
07	1	P520074	Head Locking Screw Spring
08	8	P840540	1/4" Flat Washer, Plated
09	7	P840915	Rubber Grommet, Z-399
10	1	P840710	1/4-20 Hex Nut
11	1	P840785	4 Prong Black Fingernut
12	1	P620003	Table Top, M700XL
13	11'	9P520001	1" Wide x 7/16" Thick Adhesive Back Neoprene Strip
14	6	P840059	Screw, 1/4-20 x 2 1/2" Lg. Socket Head
15	9	P840203	Screw, #8-32 x 1/2" Lg. Type F Hex Head
16	1	P620055	Pantograph Pan
17	1	P520053	Drip Pan
18	1	P840730	#8-32 Hex Nut
19	1	P630300	DC Motor Assembly
20	1	P530414	CPU Power Supply Cover
21	1	P530400	CPU Power Supply Assembly
22	2	P520062	3" Dia. x 1 1/4" Wide Durafoam Wheel
23	4	P840603	Bolt, 5/16-18 x 1" Lg. Hex Head
24	8	P840561	5/16" Flat Washer
25	4	P840582	5/16" Lockwasher, Split
26	4	P840707	5/16-18 Hex Nut
27	2	P520066	Axle, Wheel
28	2	P520064	Locknut, Wheel
29	4	P840410	Screw, Mach. #6-32 x 3/8" Lg. Slotted Pan Head

Fig. 7-15: Pantograph & Head Locking Screw Installation

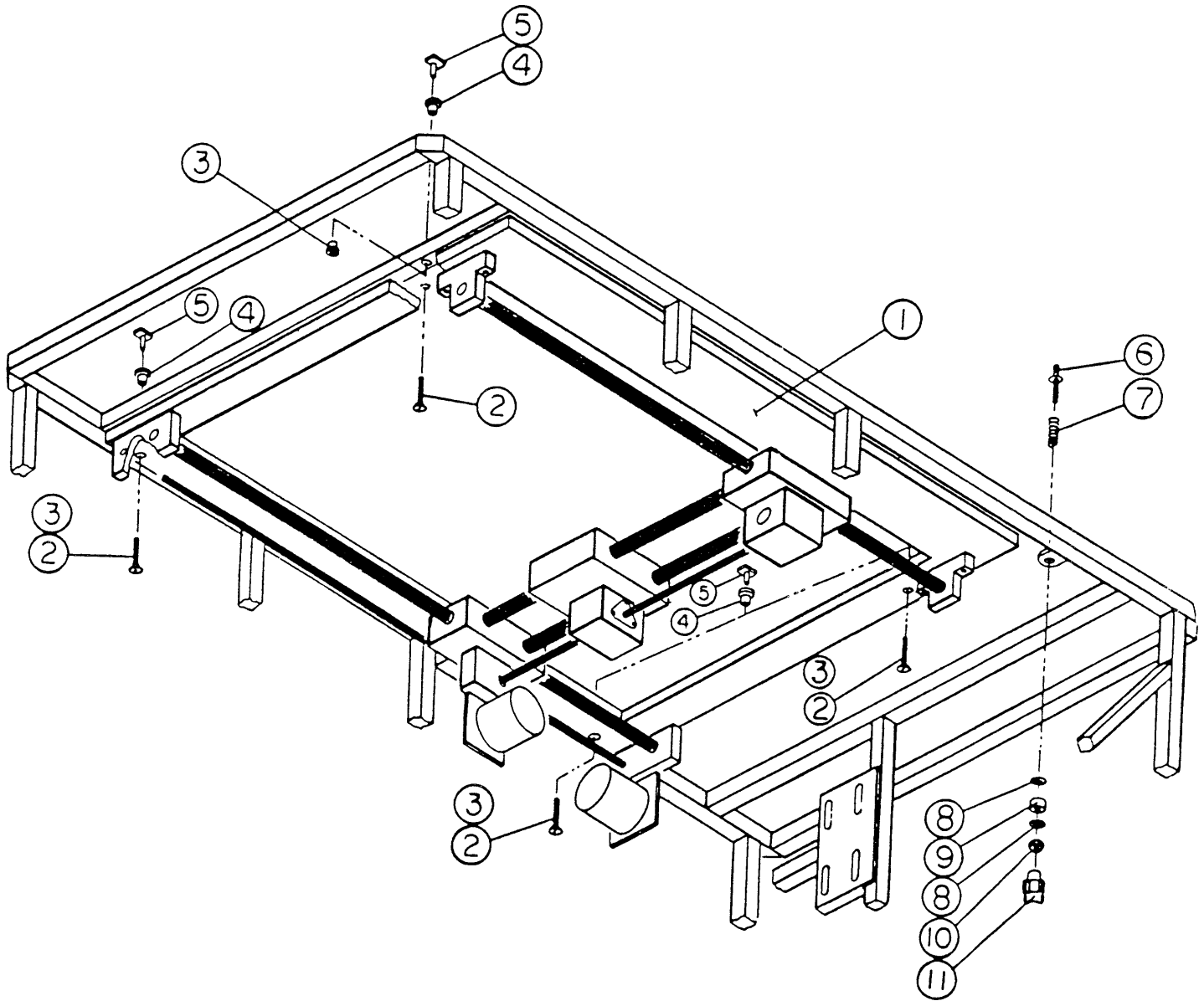

Fig. 7-16: Table Top Installation

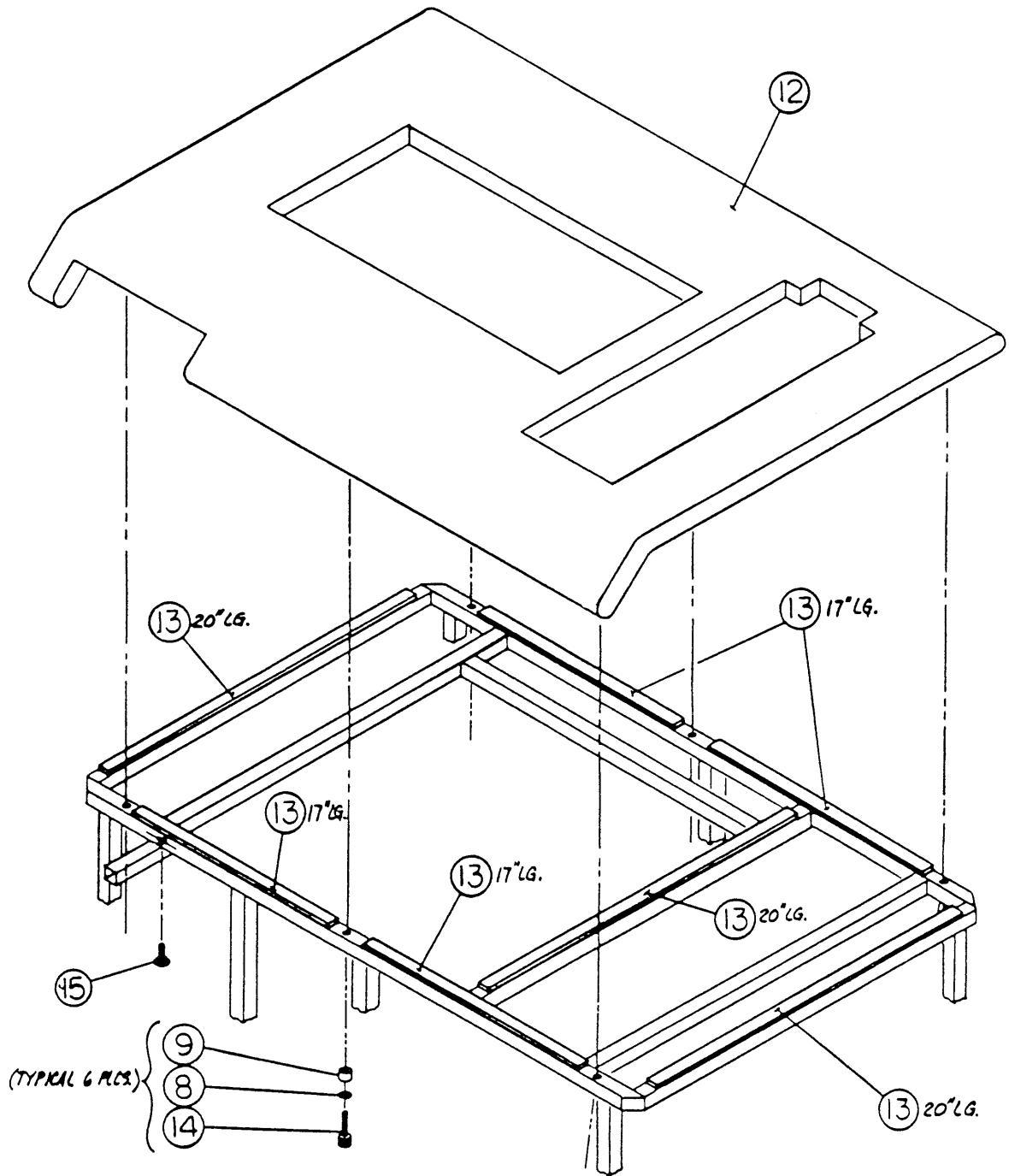
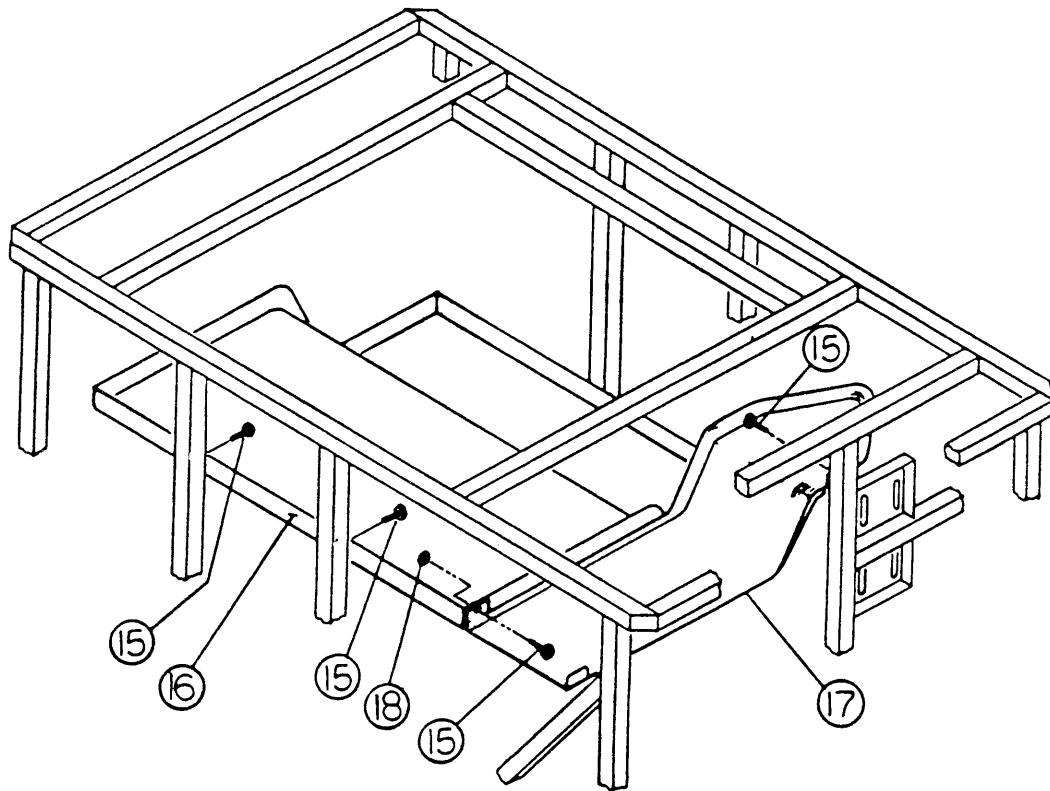

TABLE TOP INSTALLATION

Fig. 7-17: Drip Pan Installation



DRIP PAN INSTALLATION

Fig. 7-18: CPU Power Supply, D.C. Motor & Wheel Installation

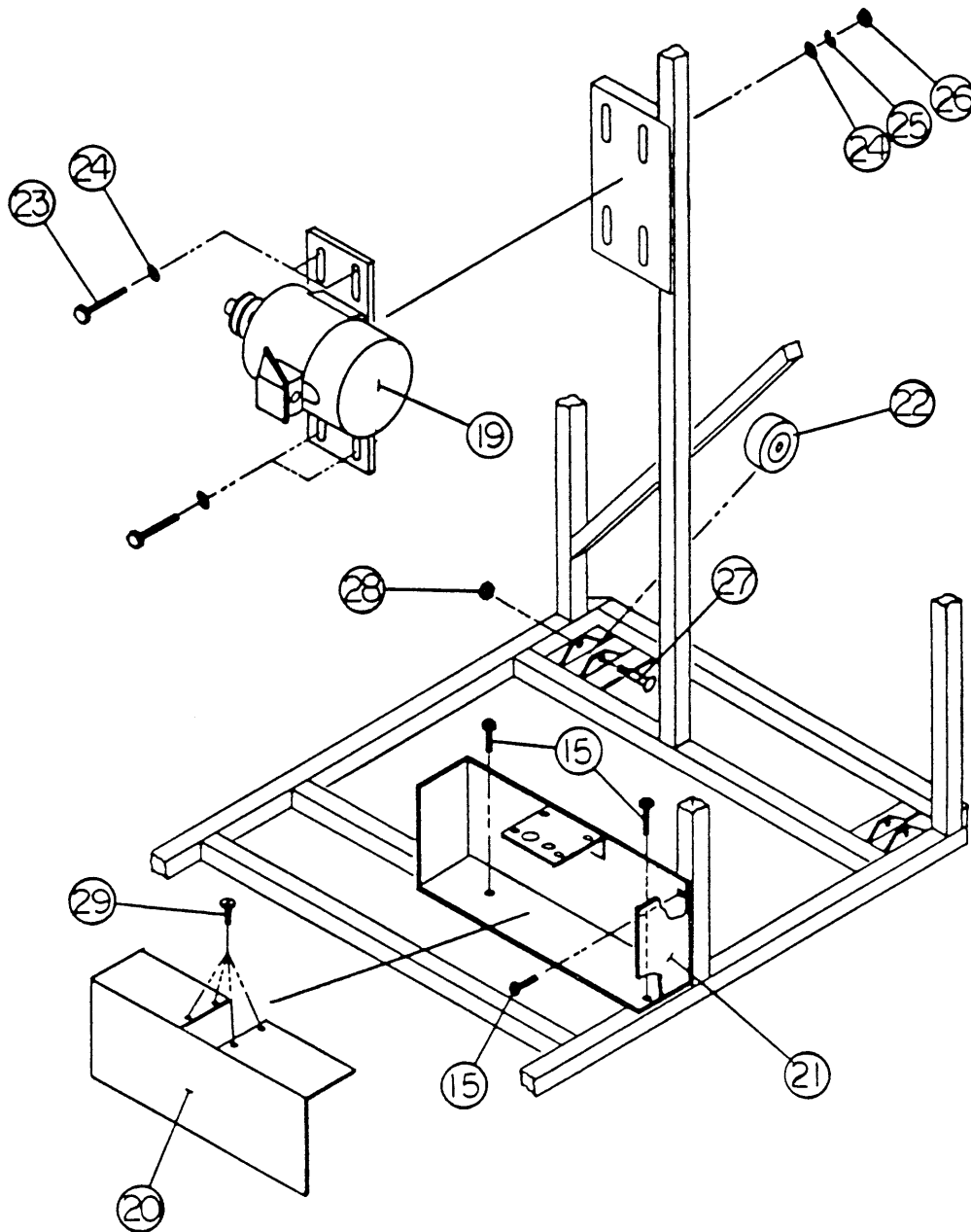

CPU POWER SUPPLY, DC MOTOR & WHEEL INSTALLATION

7.1.7. XL Electrical Wiring

ASSEMBLY NAME: XL Electrical Wiring ASSEMBLY FIG. NO.: 7.19
7.20
7.21
7.22

REF.	QTY.	PART NO.	DESCRIPTION
01	1	P530750	Main Frame Harness
02	1	P630755	Pantograph Limit Harness
03	1	P630710	Ribbon Cable, Head Interface
04	1	P630715	Display Power Harness
05	1	P530730	Ribbon Cable, PE to CLC
06	1	P530725	Ribbon Cable, Console To CLC
07	1	P530503	Diode Harness

Fig. 7-19: Electrical Wiring - Front View

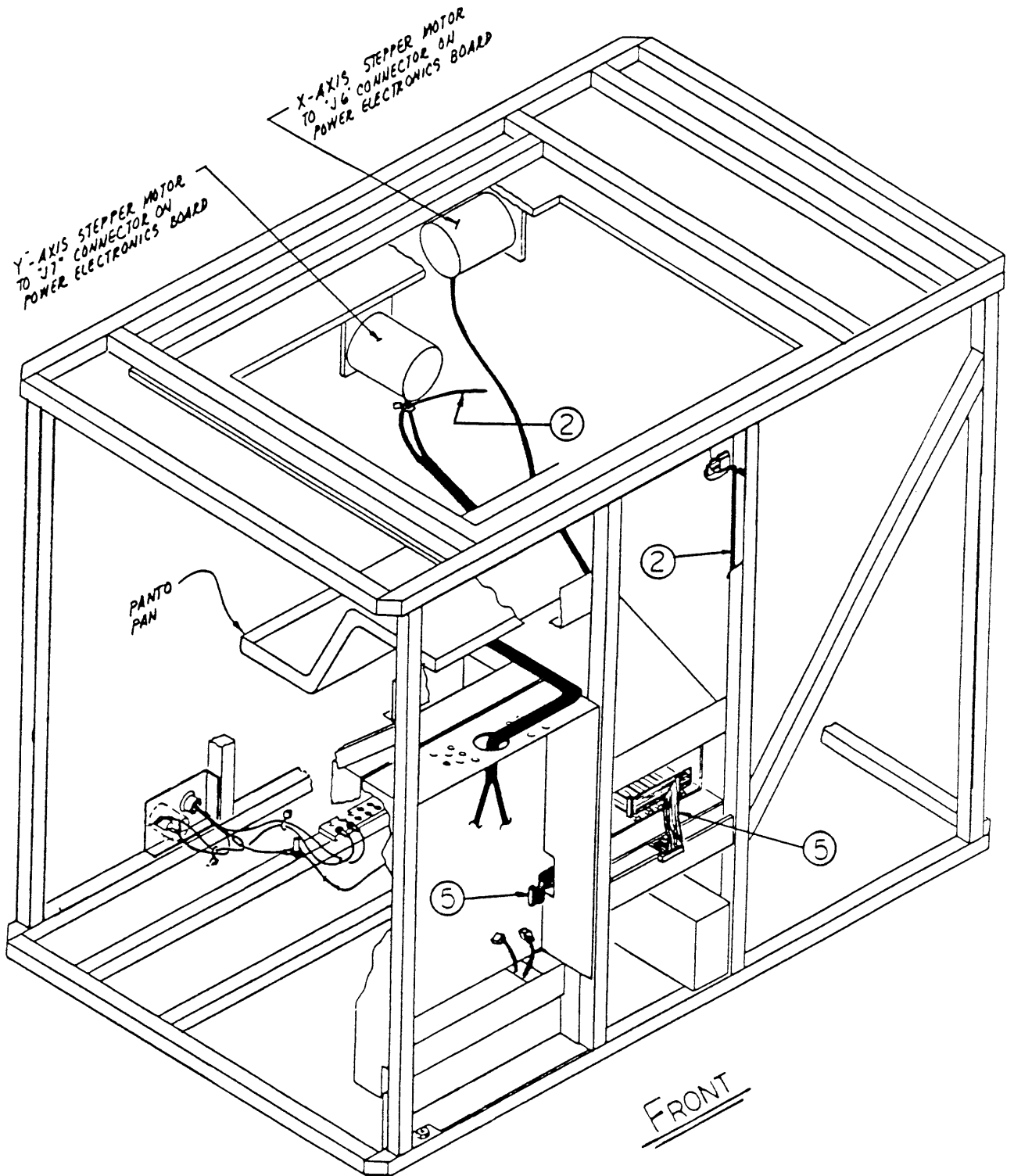

Fig. 7-20: Electrical Wiring - Side View

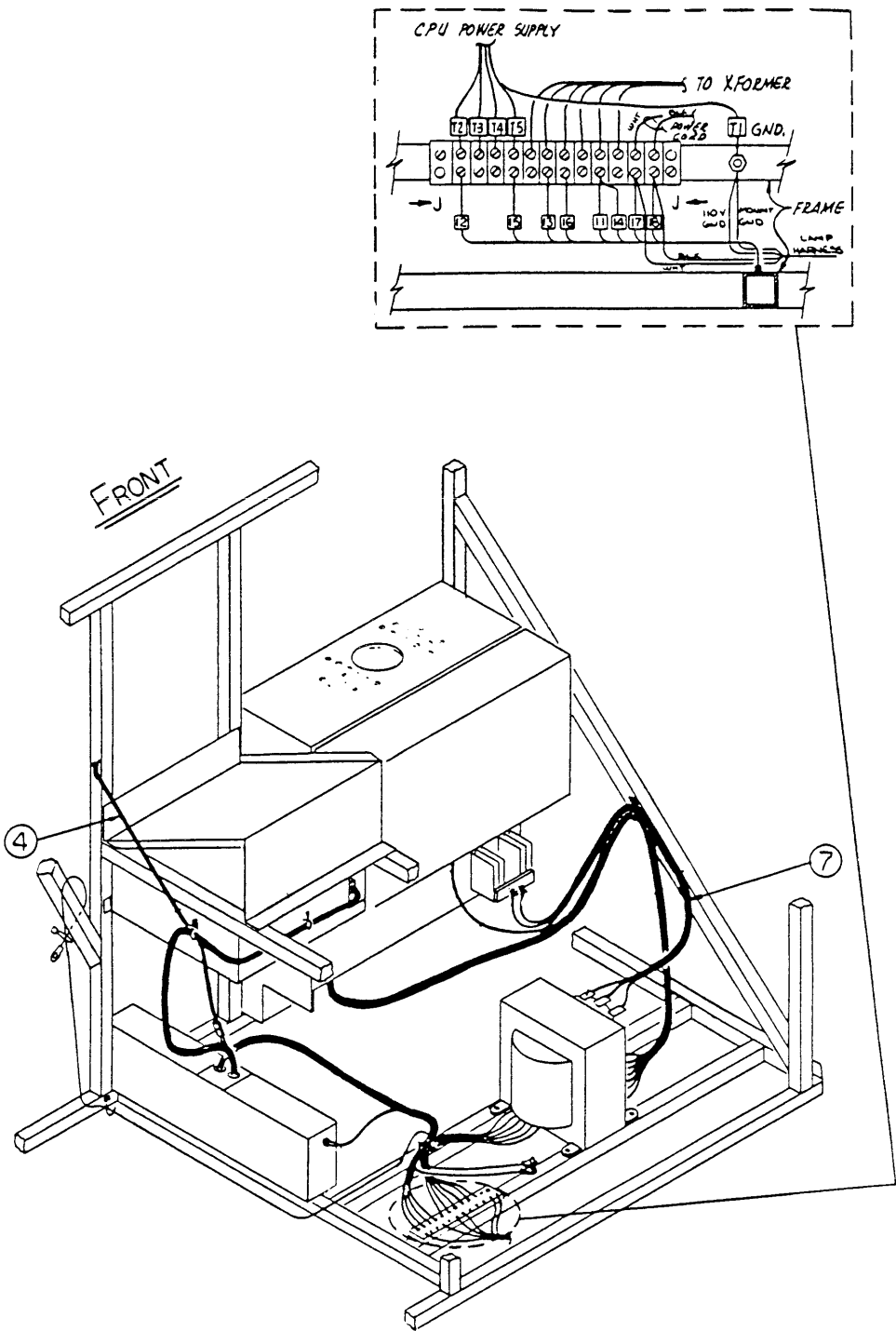

Fig. 7-21: Electrical Wiring - Bottom View

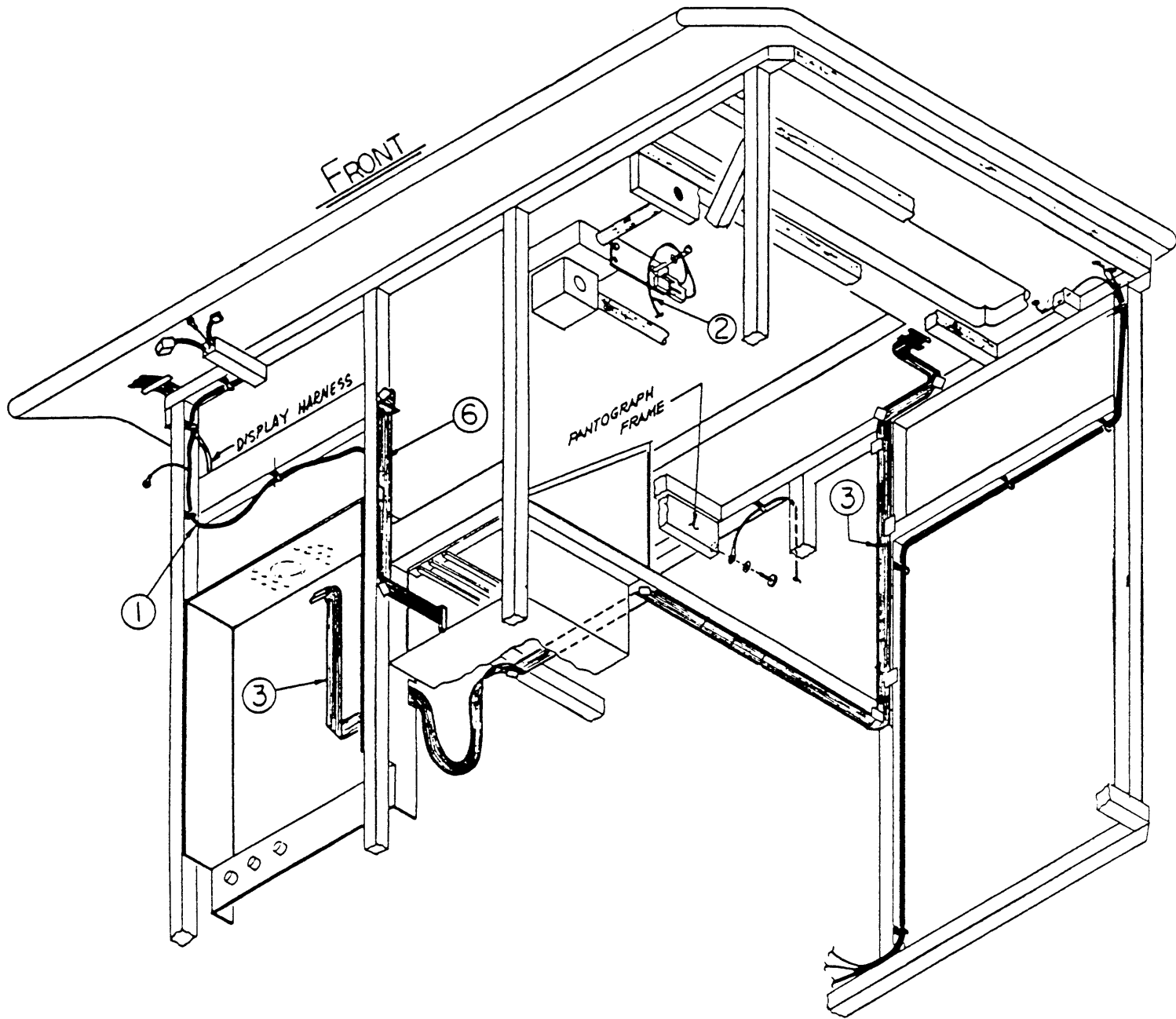
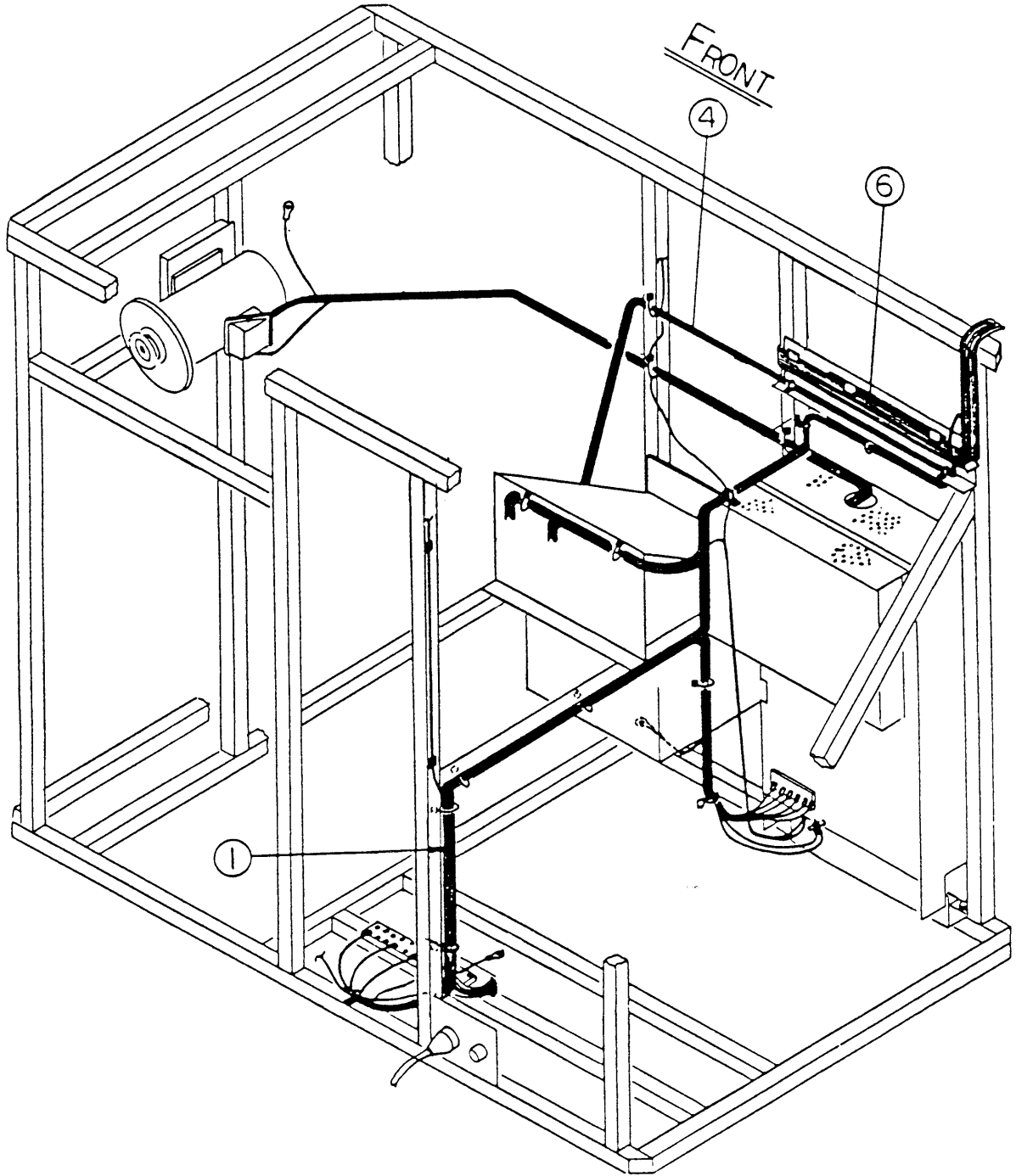

Fig. 7-22: Electrical Wiring - Rear View



7.1.8. XL Control Console Assembly

ASSEMBLY NAME: XL Control Console
Assembly

ASSEMBLY FIG. NO.: 7.23
7.24

REF.	QTY.	PART NO.	DESCRIPTION
01	1	P530100	Control Console Assembly
02	1	P630102	Control Housing Set
03	1	P520012	Switch, Illuminated Power
04	1	P520016	Safety Switch DPST
05	1	P520018	Switch, Stop
06	1	P520020	Red Button, Stop Switch
07	1	P840562	7/16" Flat Washer, 1/2" I.D. x 1" O.D.
08	1	P530129	Console Switch Shield
09	1	P530716	Display Power Harness, Short
10	1	P530125	Tape Drive
11	1	P530108	Keyboard
12	2	P520029	Mounting Bracket, Keyboard
13	1	P330440	Display
14	1	P530103	Filter, Display
15	1	P530735	Ribbon Cable, Keyboard to Display
16	1	P840505	#4 Lockwasher, Internal Tooth
17	1	P530785	Console Stop Switch Harness
18	13	P840511	#6 Lockwasher, Internal Tooth
19	2	P520081	Screw, #6-32 x 5/8" Lg. Decorative Head
20	12	P840150	Screw, #6-32 x 1/4" Lg. Phillips Round Hd
21	1	P840410	Screw, #6-32 x 3/8" Lg. Slotted Pan Head
22	1	P530795	Console Power Harness
23	16"	9P891300	22 Ga. Wire, Green
24	1	P630139	Bezel, Display
25	1	9P530400	Fish Paper

Fig. 7-23: Control Console Assembly

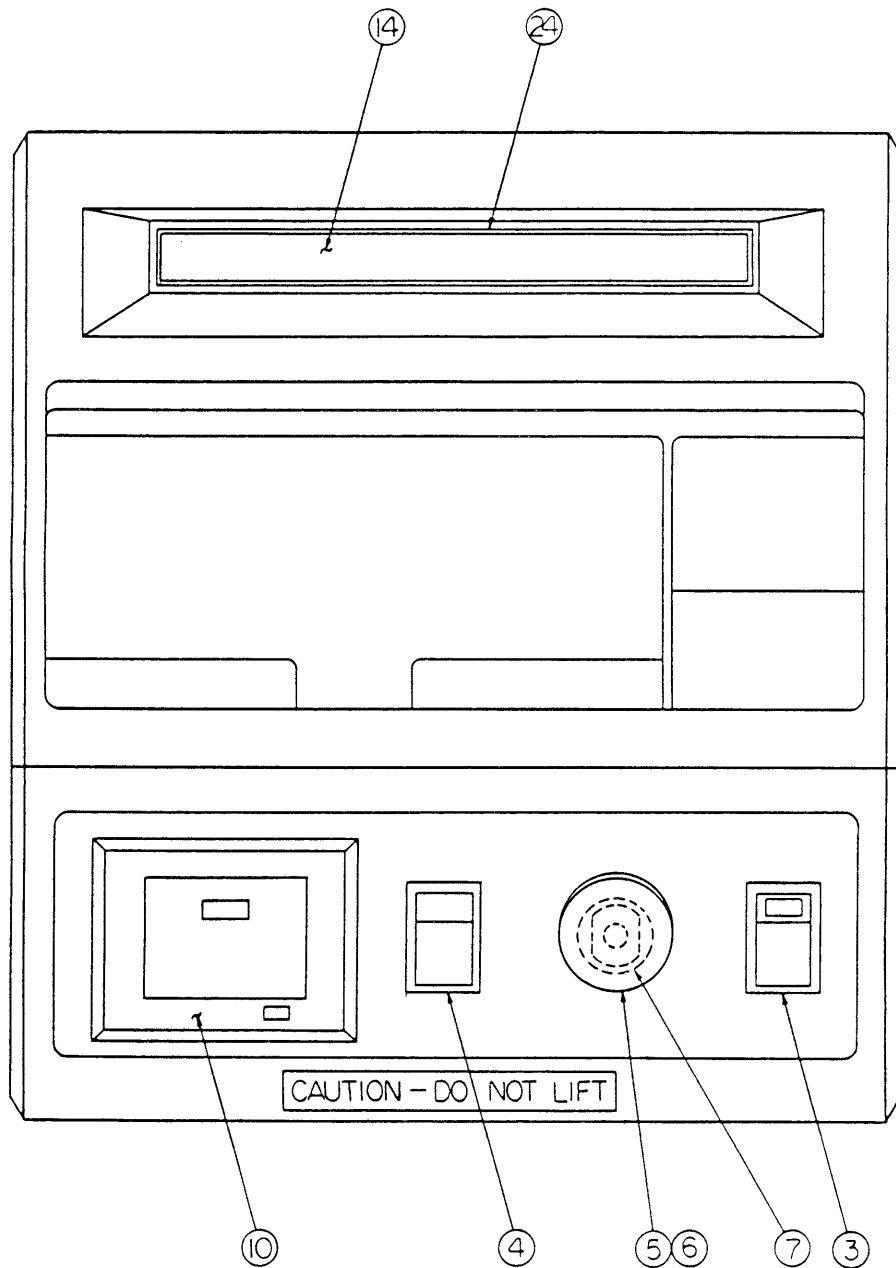
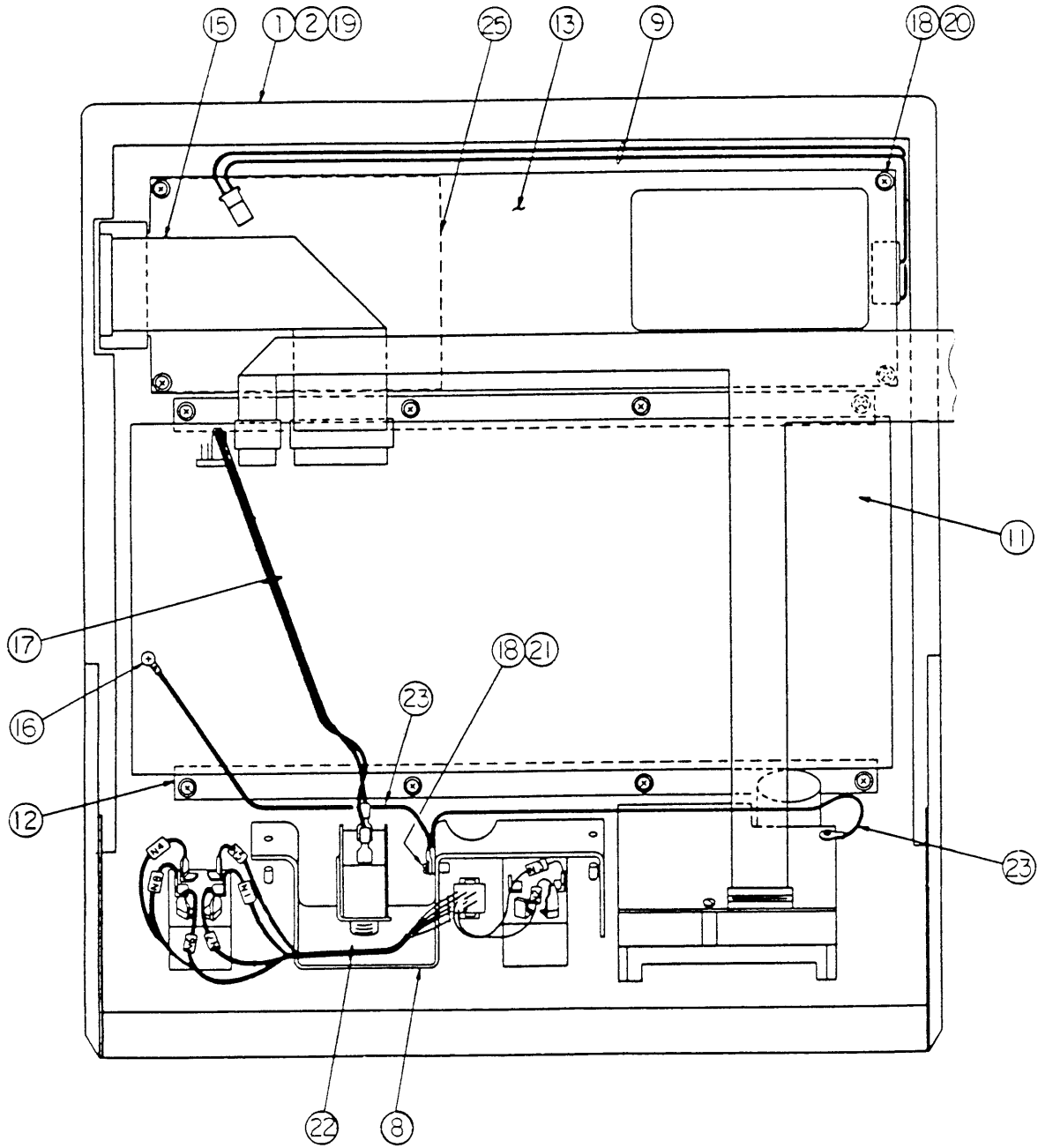

Fig. 7-24: Control Console Assembly



7.1.9. XL Power Control Assembly

ASSEMBLY NAME: XL Power Control Assy. ASSEMBLY FIG. NO.: 7.25
7.26
7.27

REF.	QTY.	PART NO.	DESCRIPTION
01	1	P530200	Power Control Assembly
02	1	P530201	Power Control Enclosure
03	1	P530203	D.C. Motor Drive Board
04	1	P530117	P.E. Board
05	1	P530119	M.C. Board
06	2	P530221	1.5 Ohm 50 Watt Power Resistor
07	4	P530217	1.2 Ohm 100 Watt Power Resistor
08	1	P530220	10 Ohm 25 Watt Power Resistor
09	2	P530120	54,000 mfd at 20V D.C. Capacitor
10	2	P530205	Mounting Bracket, Capacitor
11	1	P530765	Power Control Harness
12	2	P330448	Line Filter, 120/240V at 5 Amp
13	1	P530340	Diode Heat Sink Assembly
14	4	P530227	Teflon Insulator
15	3	P335167	Fuse Holder
16	6	P840520	#8 Flat Washer
17	12"	9P530200	Grommet Strip
18	4	P840167	Sheet Metal Screw, #6 x 1/4" Lg. Slotted Pan Head
19	8	P840169	Sheet Metal Screw, #6 x 1/2" Lg. Slotted Pan Head
20	1	P840917	1/2" Plastic Bushing
21	30	P840511	#6 Lockwasher, Internal Tooth
22	10	P840410	Screw, #6-32 x 3/8" Lg. Slotted Pan Hd.
23	10	P840725	#6-32 Hex Nut, Small Pattern
24	6	P840404	Screw, #4-40 x 3/8" Lg. Slotted Pan Hd.
25	7	P840631	#8-32 x 5/8" Lg. Self-Clinch Stud
26	7	P840523	#8 Lockwasher, Split
27	15	P840732	#8-32 Hex Nut, Small Pattern
28	17	P840420	Screw, #10-32 x 3/8" Lg. Slotted Pan Hd.
29	17	P840576	#10 Lockwasher, Internal Tooth, Brass
30	8	P840450	Screw, #8-32 x 3/8" Lg. Slotted Pan Hd.
31	10	P530213	Standoff, #6-32 x 1" Lg. Hex Male-Female
32	9	P840508	#8 Lockwasher, Internal Tooth
33	6	P840505	#4 Lockwasher, Internal Tooth
34	6	P840715	#4-40 Hex Nut
35	1	P530775	KBIC Harness
36	1	P530780	MC-PE Harness
37	1	P530790	Resistor Harness

Fig. 7-25: Power Control Assembly Front View

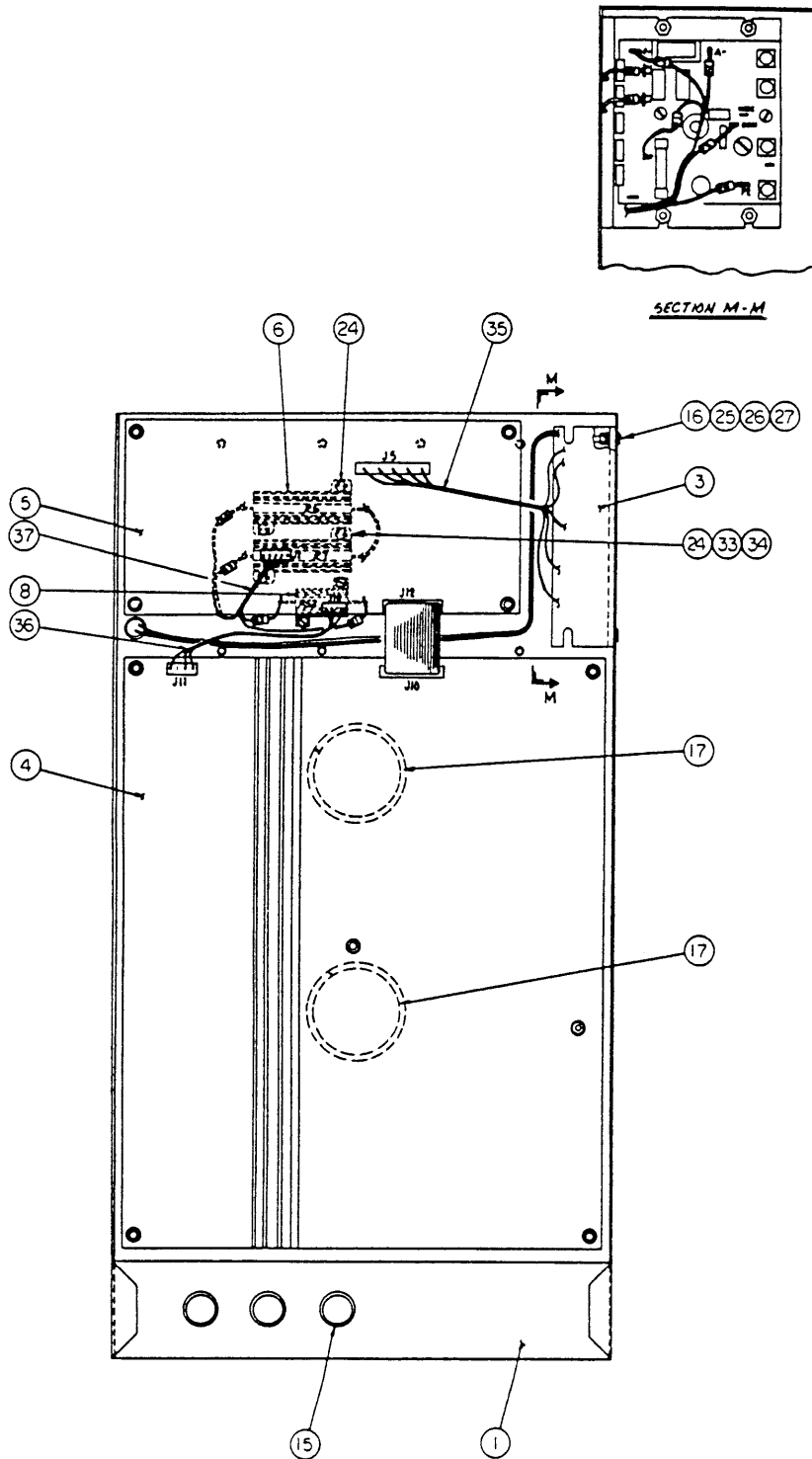

Fig. 7-26: Power Control Assembly Rear View

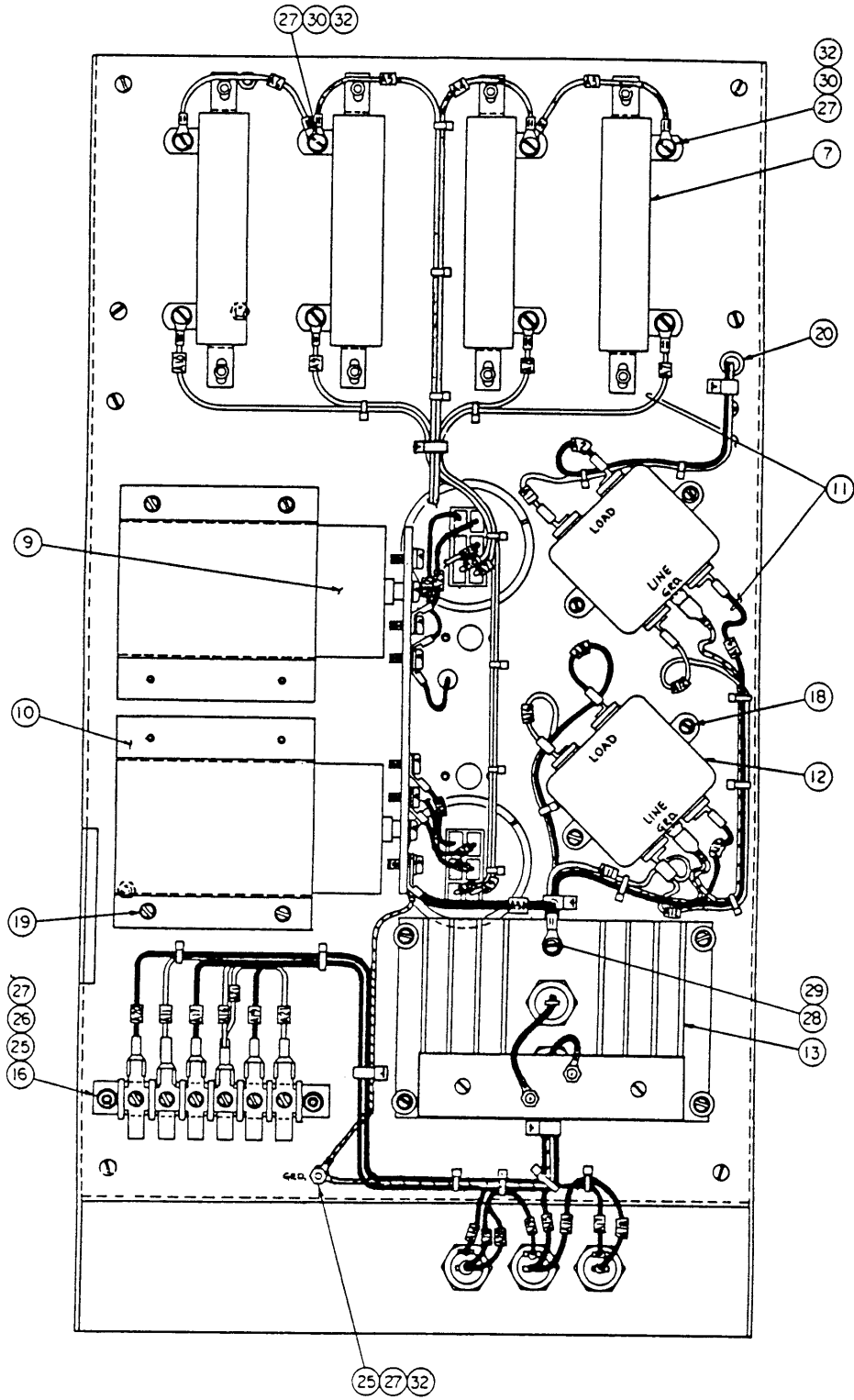
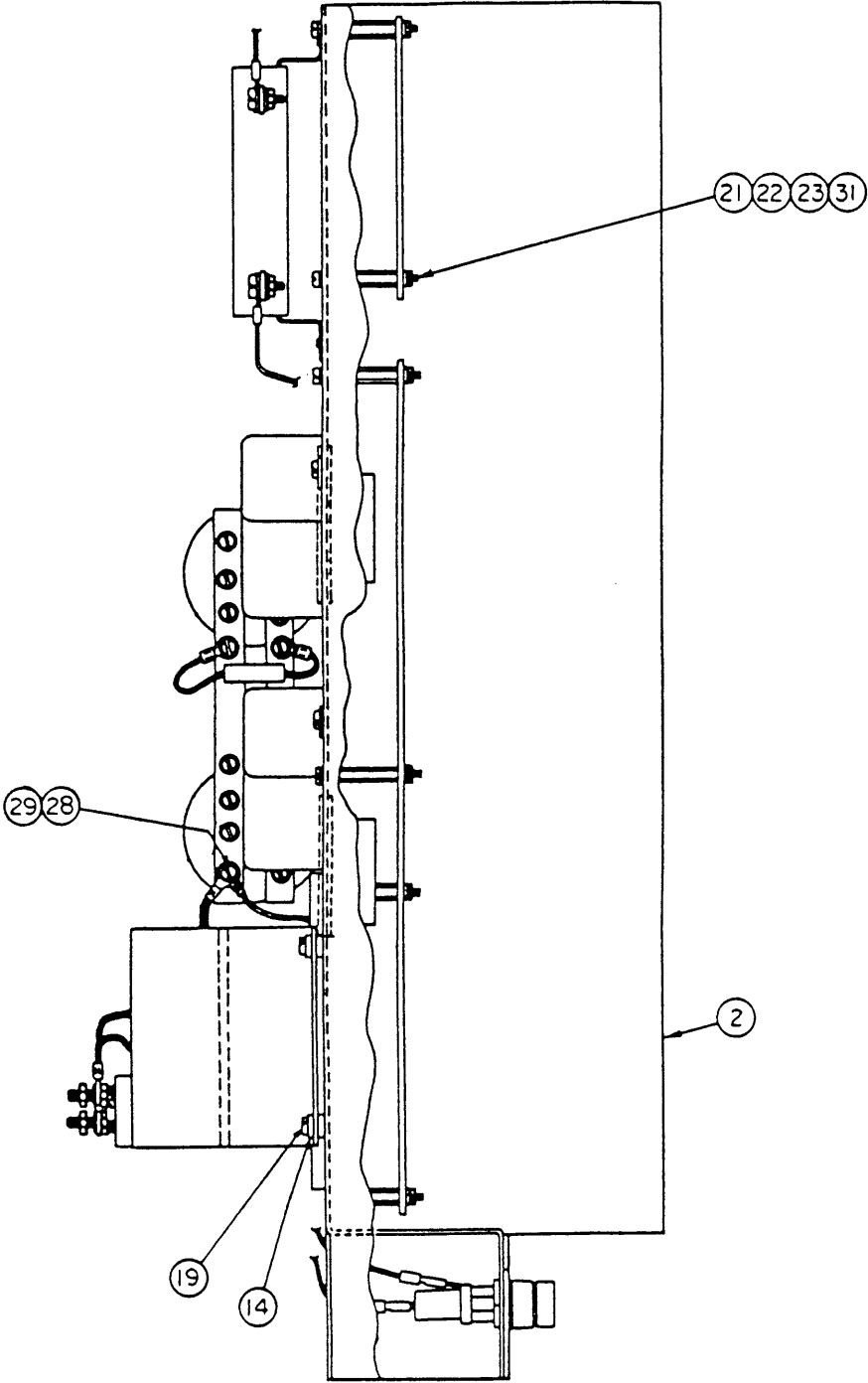

Fig. 7-27: Power Control Assembly Side View



7.1.10. XL Sewing Head Top Cover, Face Plate, Thread Guide & Thread Tension

ASSEMBLY NAME: XL SEWING HEAD ASSEMBLY FIG. NO.: 7.28
TOP COVER, FACE PLATE,
THREAD GUIDE & THREAD TENSION

REF.	QTY.	PART NO.	DESCRIPTION
6031	2	P413225	Throat Plate Screw
8060	1	P413240	Screw
10551	1	P413298	Needle Bar Connecting Link Rear Guard
10650	2	P413385	Screw
10675	1	P413405	Tension Bracket
10678	2	P413408	Tension Release Lever
10679	2	P413409	Tension Release Lever Screw
10682	1	P413411	Thread Guide Upper
10685	3	P413414	Screw
10691	2	P413420	Thread Disk
10692	1	P413421	Tension Release Washer
10694	1	P413423	Thread Controller Disk
10695	1	P413424	Disk Screw
10697	3	P413426	Tension Thumb Nut
10789	1	P413489	Tension Stud
10791	1	P413491	Tension Bracket Pin
10792	1	P413492	Thread Controller Stud
10793	1	P413493	Tension Release Plunger
11006	1	P413503	Thread Guide, Top Cover
11160	1	P413525	Thread Guide, Middle
12048	1	P413529	Tension Release Spring
13076	1	P413541	Nut For Upper Thread Guide
15004	1	P413551	Top Cover Gasket
15007	7	P413553	Screw
15025	1	P413557	Take Up Lever Guard
15035	1	P413565	Face Plate
15036	1	P413566	Face Plate Hinge
15037	1	P413567	Face Plate Spring
15038	2	P413568	Rubber Plug
15039	8	P413569	Screw
15055	1	P413571	Screw
15062	1	P413578	Thread Retainer
35504	1	P413750	Top Cover
35556	1	P413805	Throat Plate
35557	1	P413806	Throat Plate Locating Pin
35578	1	P413842	Spring
35582	1	P413846	Tension Release Lever Rod
35585	1	P413849	Thread Guide, Lower
35612C	1	P614065	Thread Break Sensor Assembly
90000	1	P614010	Tension Release Solenoid Assembly

Fig. 7-28: Top Cover, Face Plate, Thread Guide & Thread Tension

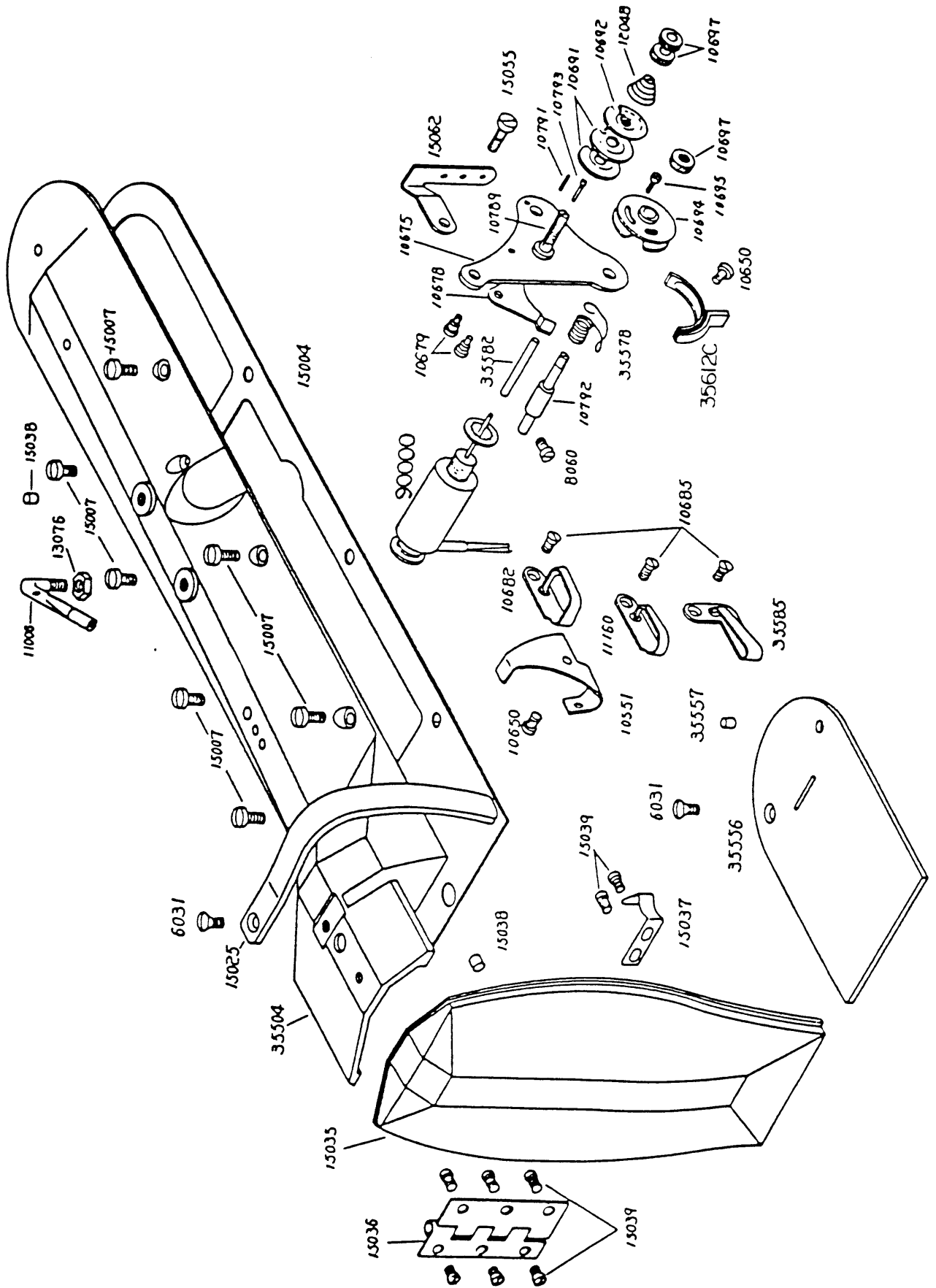

7.1.11. XL Sewing Head Arm Shaft & Thread Take Up

ASSEMBLY NAME: XL SEWING HEAD ASSEMBLY FIG. NO.: 7.29
ARM SHAFT & THREAD TAKE UP

REF.	QTY.	PART NO.	DESCRIPTION
10504	1	P413250	Balance Wheel
10506	1	P413252	Arm Shaft Oil Packing Stop Screw
10520	1	P413266	Needle Bar Crank
10521	1	P413267	Screw
10522	1	P413268	Set Screw
10523	1	P413269	Needle Bar Connecting Link Stud
10524	4	P413270	Set Screw
10528	1	P413274	Needle Bar Connecting Link
10562	1	P413310	Arm Shaft Bushing, Front
10563	1	P413311	Arm Shaft Bushing, Front Washer
10566	3	P413314	Set Screw
10571	3	P413319	Set Screw
10576	1	P413324	Screw
10577	1	P413325	Balance Wheel Adjusting Screw
10579	1	P413327	Set Screw
10725	4	P413437	Oil Felt
10726	1	P413438	Oil Wick
10728	1	P413439	Oil Wick
10729	1	P413440	Oil Wick
10764	1	P413464	Set Screw
10766	2	P413466	Set Screw
10771	1	P413471	Lifting Eccentric
11012	1	P413509	Oil Wick
11042	1	P413515	Oil Wick
13081	1	P413543	Oil Felt
13423PB	1	P413549	Stitch Length Indicator
15013	1	P413555	Take Up Lever Hinge Stud
15026	1	P413559	Take Up Lever Drive Stud
15033	1	P413563	Oil Wick for Arm Shaft
15034	1	P413564	Oil Wick Holder
15038	1	P413568	Rubber Plug
17011	1	P413601	Arm Shaft
17012	1	P413602	Arm Shaft Bushing, Middle
17013	1	P413603	Arm Shaft Bushing, Rear
17014	1	P413604	Arm Shaft Bushing Collar
17017	1	P413607	Arm Shaft Gear, Spiral
17018	1	P413608	Set Screw
17019	1	P413609	Set Screw
18003	1	P413650	Thread Take UP Lever
35505	1	P413751	Feed Fork Collar
90001	1	P614030	PT/NPS Sender Assembly
90002	1	P614040	PT/NPS Pick Up Assembly

7.1.12. XL Sewing Head Needle Bar (Swing Mechanism)

ASSEMBLY NAME: XL SEWING HEAD ASSEMBLY FIG NO.: 7.30
NEEDLE BAR (SWING MECHANISM)

REF.	QTY.	PART NO.	DESCRIPTION
4134	1	P413205	Screw
4221	1	P413213	Oil Wick Clamp
8105	3	P413247	Nut
10519	1	P413265	Screw
10524	2	P413270	Set Screw
10525	2	P413271	Set Screw
10531	1	P413278	Needle Bar Connecting Stud
10532	1	P413279	Screw
10537	1	P413283	Needle Bar Rock Frame Hinge Stud
10560	1	P413308	Needle Bar Rock Frame Position Bracket
10561	1	P413309	Screw
10580	1	P413328	Needle Bar Rock Frame Slide Block Stud
10581	1	P413329	Set Screw
10582	1	P413330	Needle Bar Rock Frame Slide Block
10724	1	P413436	Oil Wick
10726	1	P413438	Oil Wick
11042	1	P413515	Oil Wick
11176	4	P413527	Set Screw
12421	1	P413533	Set Screw
12626	1	P413535	Needle Screw
13084	1	P413545	Nut
15031	1	P413561	Oil Wick
15069	1	P413581	Oil Wick
15076	1	P413585	Cotter Pin
17048	1	P413638	Needle Bar Rock Frame Shaft
17063	1	P413641	Collar
18018	3	P413660	Hinge Screw
18065	2	P413699	Screw
35506	1	P413752	Stitch Width Drive Gear
35507	1	P413753	Stitch Width Cam
35508	1	P413754	Stitch Width Cam Shaft
35509	2	P413755	Shaft Collar
35512	1	P413758	Stitch Width Cam Follower
35513	1	P413759	Pivot Link
35514	1	P413760	Shaft for Pivot Link
35515	1	P413761	Shoulder Screw For Pivot Link
35536	1	P413782	Pivot Connecting Bracket
35537	1	P413783	Pivot Shaft
35538	1	P413784	Needle Bar Rock Frame Shaft Crank Conn.
35539	1	P413785	Needle Bar Rock Frame Shaft Crank
35540	1	P413786	Oil Wick
35552	1	P413799	Needle
35553	1	P413802	Needle Bar Frame
35554	1	P413803	Needle Bar
35555	1	P413860	Needle Bar Thread Guide

Fig. 7-30: Needle Bar (swing Mechanism)

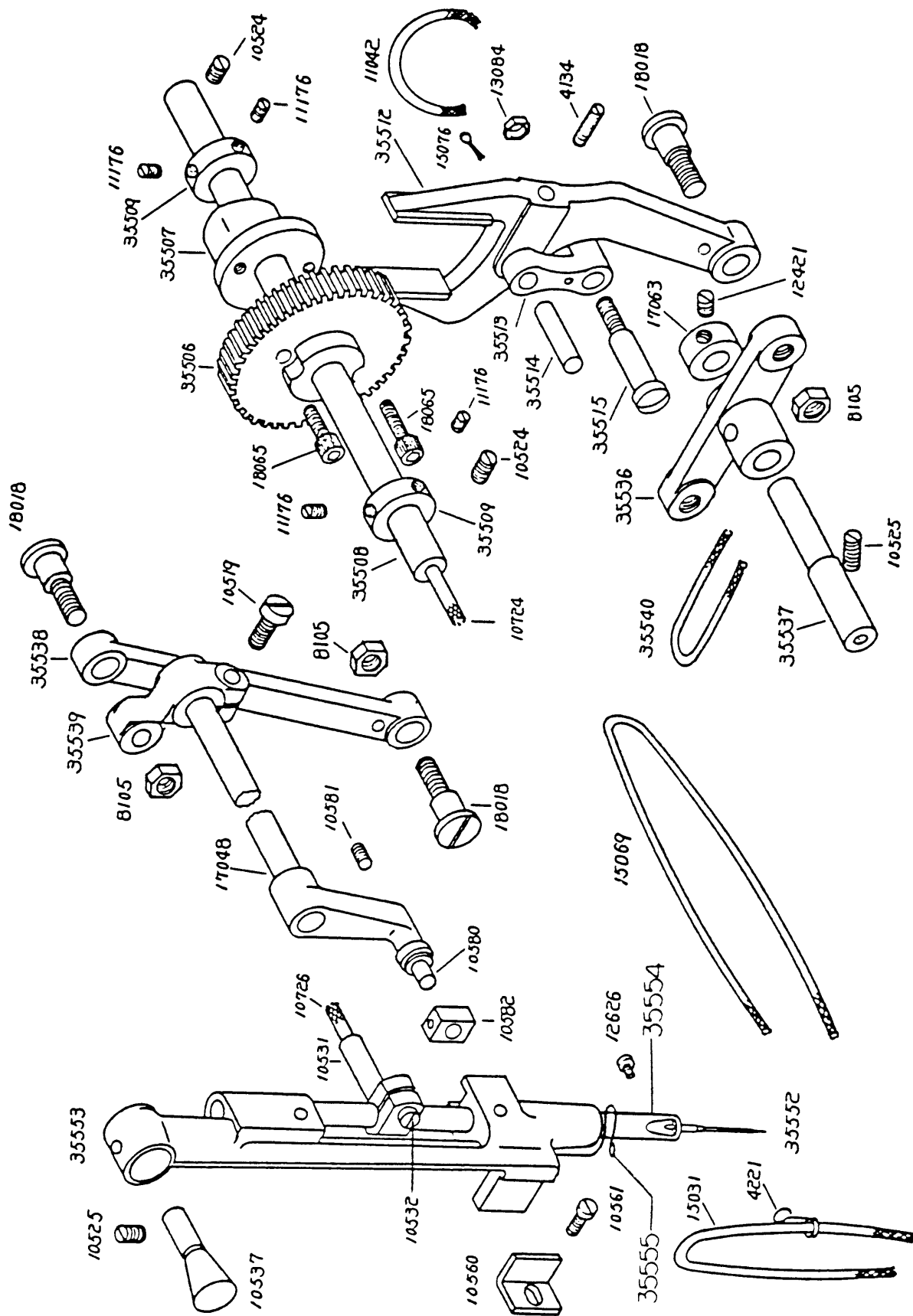

7.1.13. XL Sewing Head Presser Bar & Components

ASSEMBLY NAME: XL SEWING HEAD ASSEMBLY FIG. NO.: 7.31
PRESSER BAR & COMPONENTS

REF.	QTY.	PART NO.	DESCRIPTION
2031	1	P413203	Screw
8146	2	P413249	Nut
10514	2	P413260	Sleeve Bearing
10532	1	P413279	Screw
10538	2	P413284	Presser Bar Bushing
10541	1	P413287	Presser Bar Position Guide Bracket
10543	1	P413289	Presser Bar Position Guide
10545	1	P413291	Screw
10549	1	P413295	Presser Bar Spring Bracket
10628	1	P413365	Set Screw
10660	1	P413390	Screw
10662	1	P413392	Screw
10703	1	P413432	Washer
10705	1	P413434	Presser Bar Spring, Flat
10706	1	P413435	Support Screw for Presser Bar Spring
10754	2	P413454	Screw
10761	3	P413461	Set Screw
10772	1	P413472	Eccentric/Cam
10773	1	P413473	Needle Bearing
10774	1	P413474	Sleeve
10775	1	P413475	Shoulder Stud
10776	1	P413476	Wing Nut
11156	1	P413523	Presser Bar Spring Regulating Screw
12909	1	P413537	Presser Bar Eccentric Cam Link, Left
13065	2	P413539	Connecting Link Shoulder Screw
15007	2	P413553	Screw
30078	1	P413725	Nut
35541	1	P413788	Eccentric Cam Link Shaft
35542	1	P413787	Presser Bar Eccentric Cam Link, Right
35543	1	P413789	Presser Bar Lift Brkt Conn. Link, Upper
35544	1	P413790	Presser Bar Lift Brkt Conn. Link, Lower
35548	1	P413795	Presser Bar
35549	1	P413012	Presser Foot
35550	1	P413797	Presser Bar Lifter Stud
35551	1	P413798	Presser Bar Lifter Lever
35569	1	P413815	Presser Bar Lifter Bracket
35583	1	P413847	Pinch Screw
35591	1	P413855	Lifter

7.1.14. XL Sewing Head Connecting Rod, Lower Shaft & Hook

ASSEMBLY NAME: XL SEWING HEAD ASSEMBLY FIG. NO.: 7.32
CONNECTING ROD, LOWER SHAFT
AND HOOK

REF.	QTY.	PART NO.	DESCRIPTION
6025	1	P413220	Bobbin Case Pos. Finger Screw
8009	3	P413230	Set Screw
10522	1	P413268	Set Screw
10571	1	P413319	Set Screw
17020	1	P413610	Arm Shaft Upright
17021	1	P413611	Arm Shaft Upright Spiral Gear
17022	6	P413612	Set Screw
17023	1	P413613	Arm Shaft Upright Gear, Lower
17024	1	P413614	Arm Shaft Upright Bushing, Upper
17025	1	P413615	Arm Shaft Upright Bushing, Lower
17026	2	P413616	Oil Felt
17028	1	P413618	Lower Shaft Gear Spiral
18034	1	P413670	Bobbin
18037	1	P413674	Hook Shaft Bushing, Rear
18057	1	P413695	Lower Shaft Bushing
18058	1	P413696	Lower Gear Cover Complete
18059	1	P413697	Pinch Screw
18060	1	P413698	Lower Gear Cover Sealing Screw
35572	1	P413818	Hook Drive Shaft
35573	1	P413819	Hook Drive Shaft Thrust Collar
35574	1	P413820	Rotating Hook Assembly Complete
35574-1	1	P413821	
35574-2	1	P413822	
35574-3	4	P413823	
35574-4	1	P413824	
35574-5	1	P413825	
35574-6	3	P413826	
35574-7	1	P413827	Hook Screw
35574-8	1	P413828	
35575	1	P413830	Bobbin Case Assembly Complete
35575-1	1	P413831	
35575-2	1	P413832	
35575-3	1	P413833	
35575-4	1	P413834	
35575-5	1	P413835	
35575-6	1	P413836	
35575-7	1	P413837	
35575-8	1	P413838	
35575-9	1	P413839	
35576	1	P413840	Hook Supporting Plate
50200	2	P413861	Set Screw

Fig. 7-32: Connecting Rod, Lower Shaft & Hook

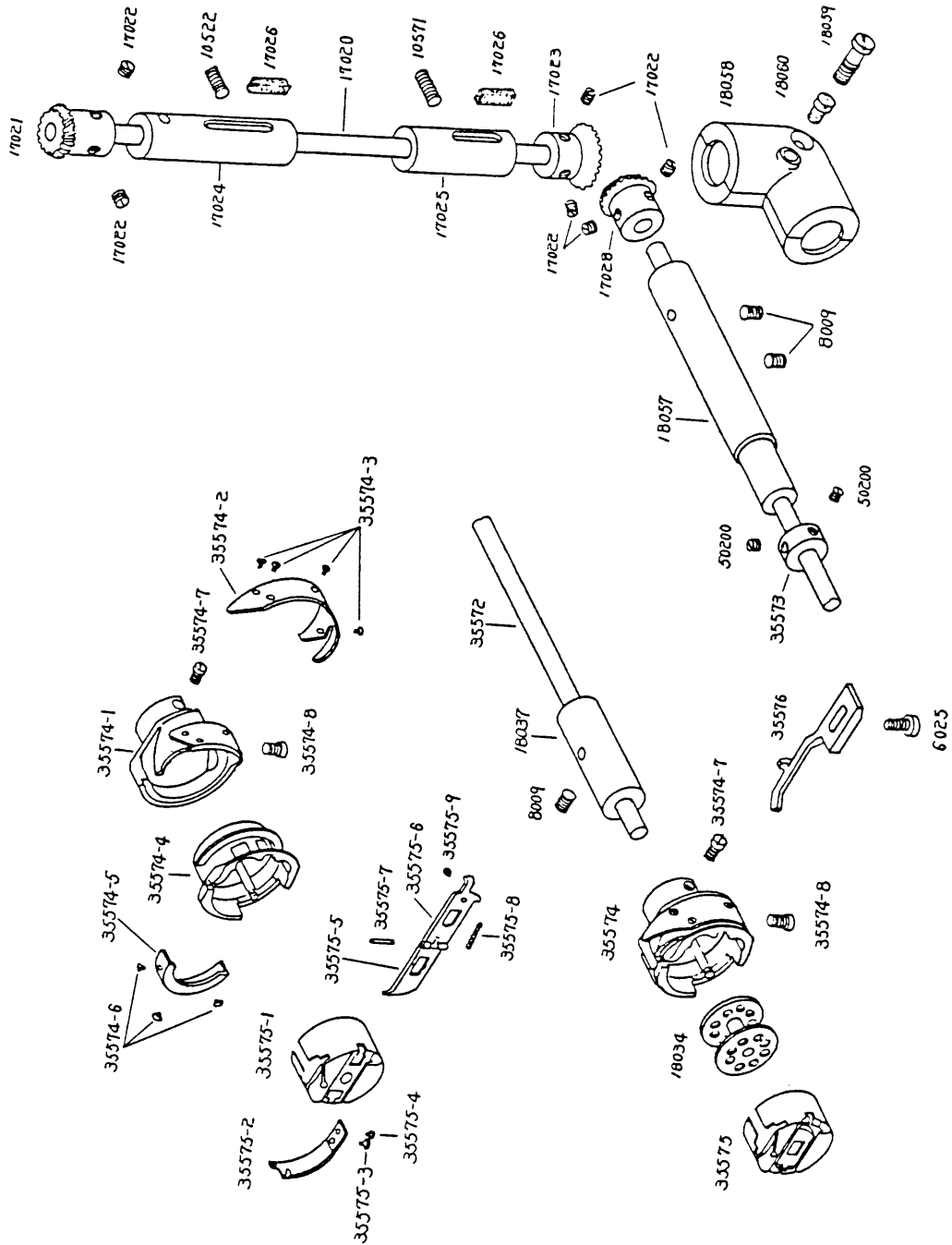

7.1.15. XL Sewing Head Stitch Width Regulation & Components

ASSEMBLY NAME: XL SEWING HEAD ASSEMBLY FIG. NO.: 7.33
STITCH WIDTH REGULATION
AND COMPONENTS

REF.	QTY.	PART NO.	DESCRIPTION
4135	2	P413206	Lock Nut
8042	1	P413237	Set Screw
8103	1	P413245	Screw
10566	2	P413314	Set Screw
10571	1	P413319	Set Screw
10766	1	P413466	Set Screw
12418	4	P413531	Cover Screw
12421	2	P413533	Set Screw
15055	1	P413571	Screw
17063	1	P413641	Collar
18065	1	P413699	Screw
31118	1	P413735	Coupling Drive Shaft Bushing
35516	1	P413762	Stitch Width Regulator Arm
35517	1	P413763	Support Shaft
35518	1	P413764	Support Shaft Bushing
35521	1	P413767	Stitch Width Indicator
35525	1	P413771	Stitch Width Assembly Cover Plate
35528	1	P413774	Lifting Crank
35529	2	P413775	Bearing Pin Connecting Bracket
35530	1	P413776	Bearing Pin, Long
35531	1	P413777	Bearing Pin, Short
35532	1	P413778	Stitch Width Regulator Connecting Arm
35533	1	P413779	Coupling Drive Shaft
90003	1	P413017	Collar
90004	1	P840405	Screw
90005	1	P413018	Magnet
90006	1	P614025	Stitch Width Limit Sensor Assembly
90007	1	P840401	Screw
90008	1	P840715	Nut
90009	1	P312013	Coupling

