

# **PARTS IDENTIFICATION**



## 7. PARTS IDENTIFICATION DRAWINGS

### 7.1. M700 Machine, less sewing head

#### 7.1.1. Frame Assembly

ASSEMBLY NAME: Frame Assembly

ASSEMBLY FIG NO.: 7.1

7.2

REF.	QTY.	PART NO.	DESCRIPTION
01	1	P514000	M700 Sewing Head Assembly
02	2	P514003	Head Hinge Pin
03	8	P840416	Screw, #6 x 5/8 Type AB, Phillips Flt Hd Chrome Plated
04	1	P520022	Back Head Hinge Plate
05	1	P520024	Front Head Hinge Plate
06	2	P520026	Rubber Hinge Insert Rubber Grommet Z399
07	1	P520200	Table Leaf Assembly, M700
08	1	P820040	V-Belt, 40"
09	1	P520009	Rear Panel With Back Hook
10	1	P520004	Left Side Panel
11	1	P520007	Front Panel with Back Hook
12	1	P520005	Right Side Panel
13	8	P840153	Screw, #6-32 x 3/8 Slotted Undercut Flat Head
14	8	P520083	Screw, #6-32 x 1/2 Type AB Phillips Decorative Head
15	1	P530823	Main Power Fuse F7; 10A, 250V
16	1	P530817	CPU Power Supply Fuse F4; 1A, 250V
17	1	P530825	Power Control Fuse F5; 8A, 250V
18	1	P530818	DC Drive Fuse F6; 5A, 250V
19	1	P530720	CPU-CLC Cable
20	1	P520033	Card Retainer
21	1	P530115	DRAM Card Assembly
22	1	P530110	CPU3 Card Assembly
23	1	P530105	Control Logic Card
24	3	P840188	Screw, #6-32 x 1/2 Slotted Pan Head
25	1	P520300	Belt Guard/Bobbin Winder Assembly

Fig. 7-1: Frame Assembly Drawing- Rear

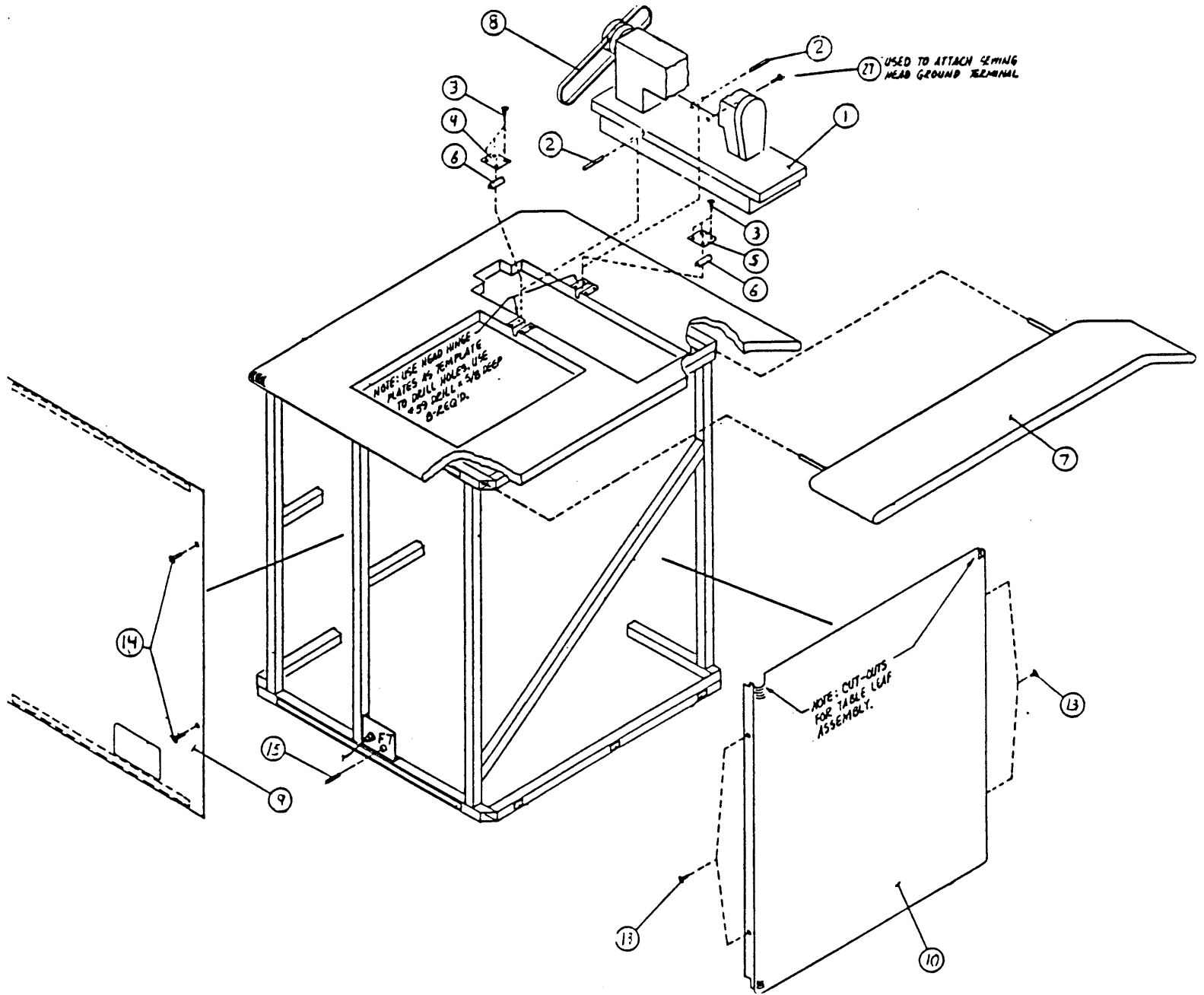
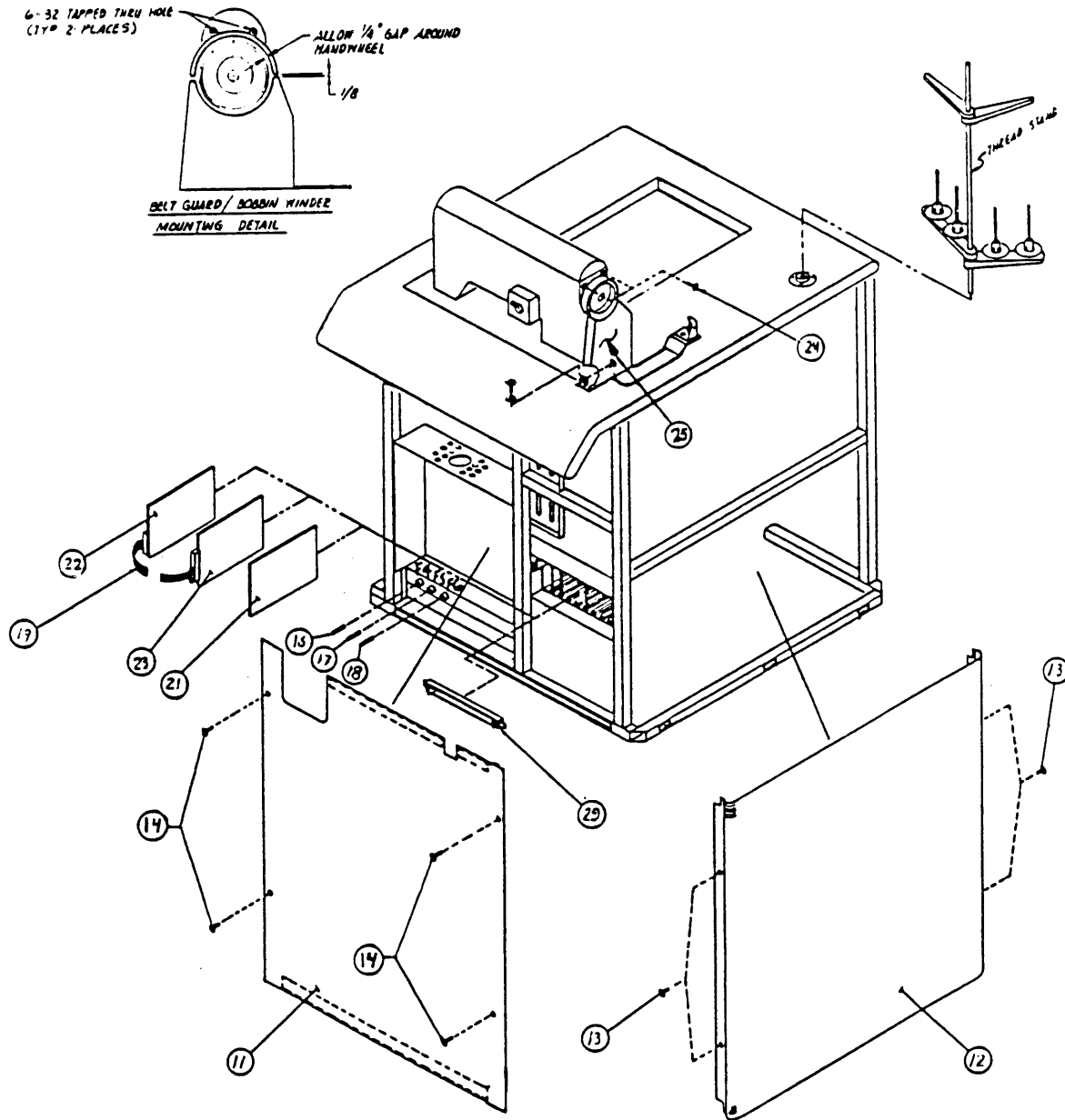

Fig. 7-2: Frame Assembly Drawing- Front



7.1.2. Table Top Assembly

ASSEMBLY NAME: Table Top Assembly

ASSEMBLY FIG. NO.: 7.3

7.4

7.5

REF.	QTY	PART NO.	DESCRIPTION
01	1		Table Top Assembly M700
02	1	P520010	Pantograph Cover Assy. with Hinges
03	4	P840307	Screw, Wood #7 x 3/4 Lg., Slotted Rd Hd Cad. Plated
04	1	P520030	Thread Stand, 4 Cone
05	1	P530100	Control Console Assembly
06	2	P520081	Screw, Mach. #6-32 x 5/8 lg. Decorative Head
07	1	P520027	Control Support Bracket, Left
08	1	P520028	Control Support Bracket, Right
09	2	P840720	#6-32 Hex Nut
10	2	P840509	#6 Lockwasher Split
11	4	P840510	#6 Flat Washer
12	2	P840530	#10 Flat Washer
13	2	P840440	Screw, Mach., #10-32 x 2 Lg. Slotted Pan Head
14	2	P520207	Leaf Latch Strike Only
15	1	P520500	Hoop Arm Assembly, M700
16	2	P840601	Bolt 5/16-18 x 3/4 Hex Head
17	2	P840582	5/16 Lockwasher, Split
18	2	P840561	5/16 Flat Washer
19	7	P840304	Screw, Wood #6-32 x 3/4 lg., Slotted Pan Head
20	1	P520501	Hoop Arm Base M700
21	2	P810056	Clamping Knob Assembly
22	1	P840625	1/4-20 x 2 1/2 Hex Head Bolt

Fig. 7-3: Sewing Head, Panto Cover & Thread Stand Installation

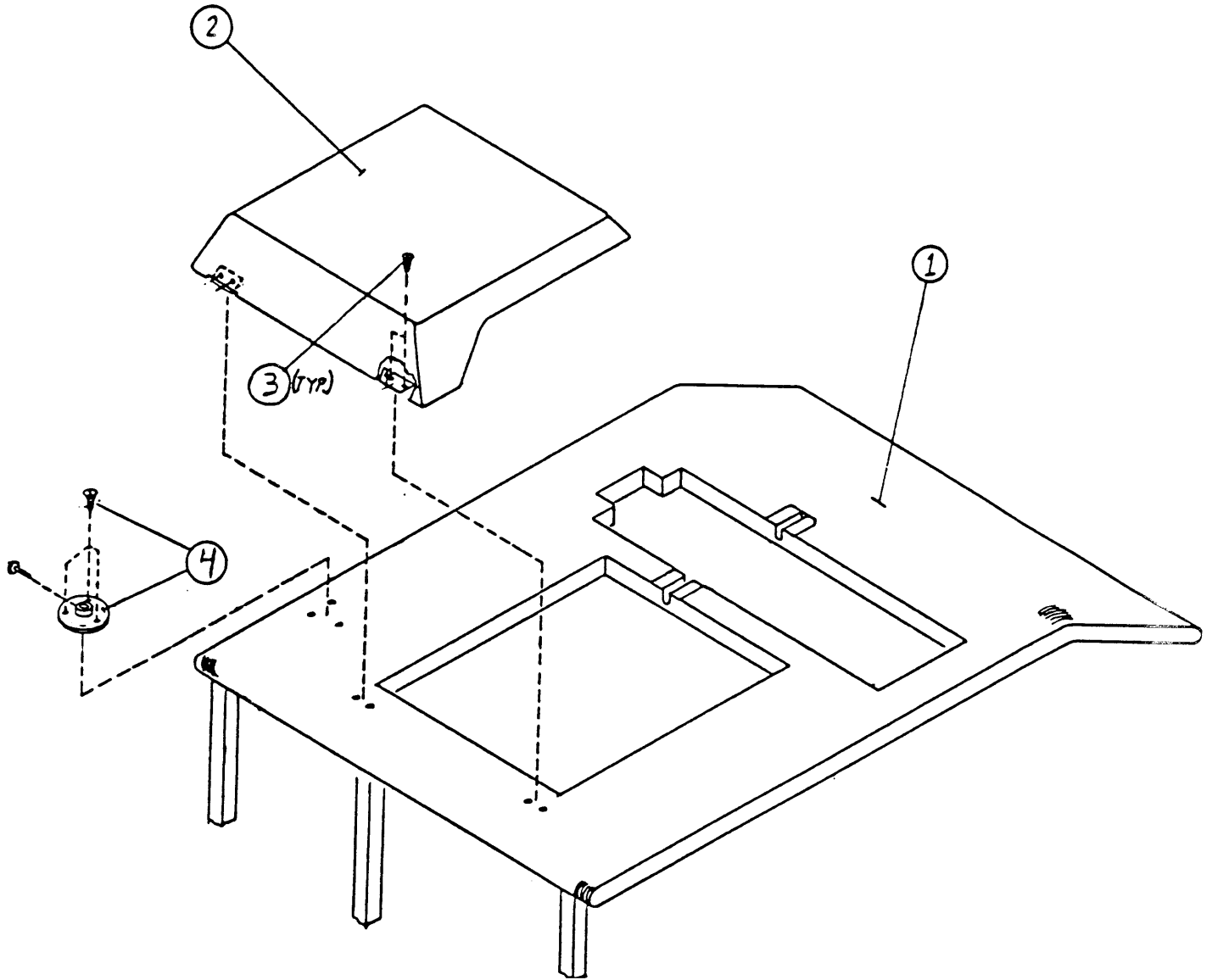

Fig. 7-4: Control Console Installation

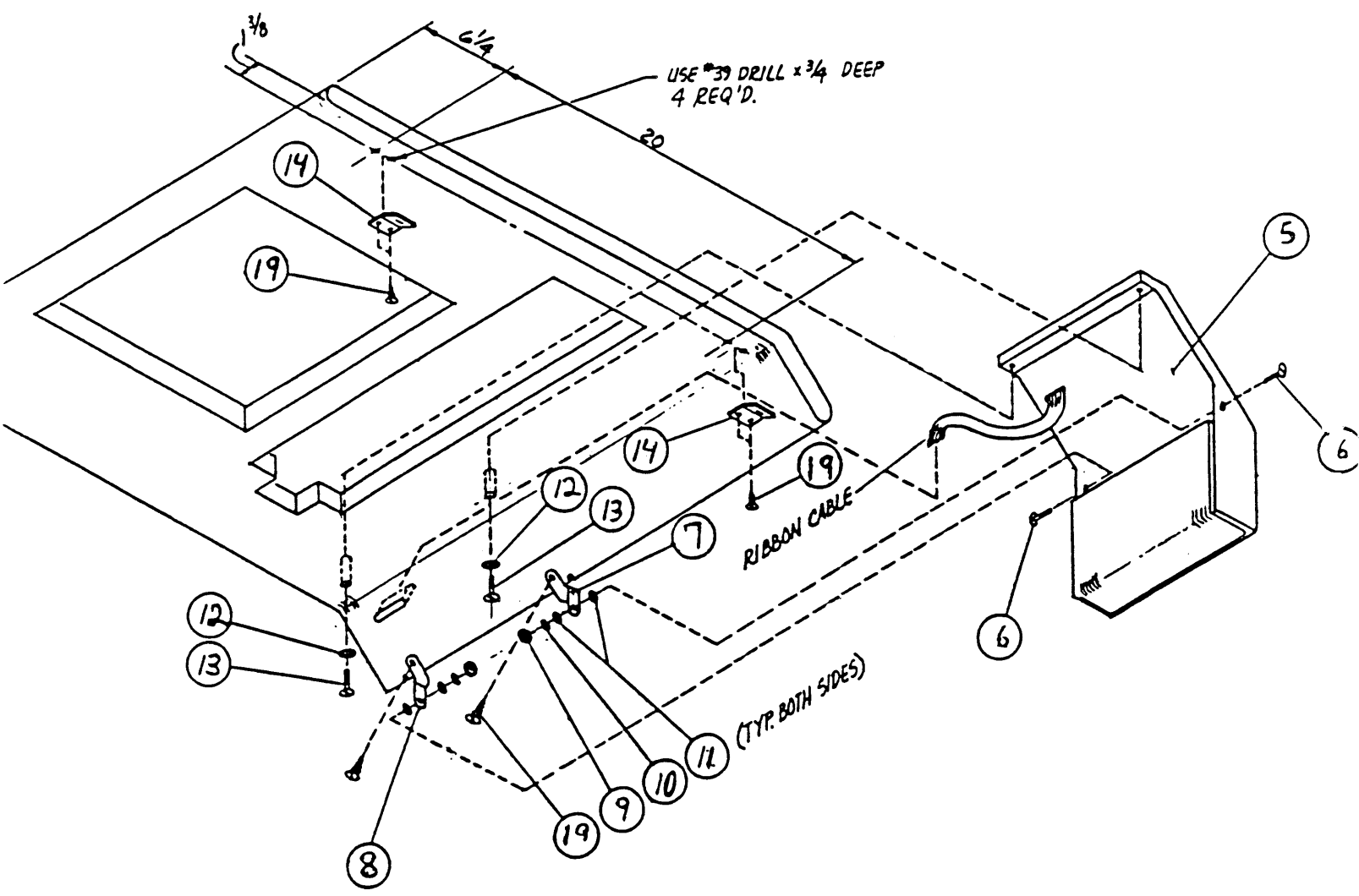
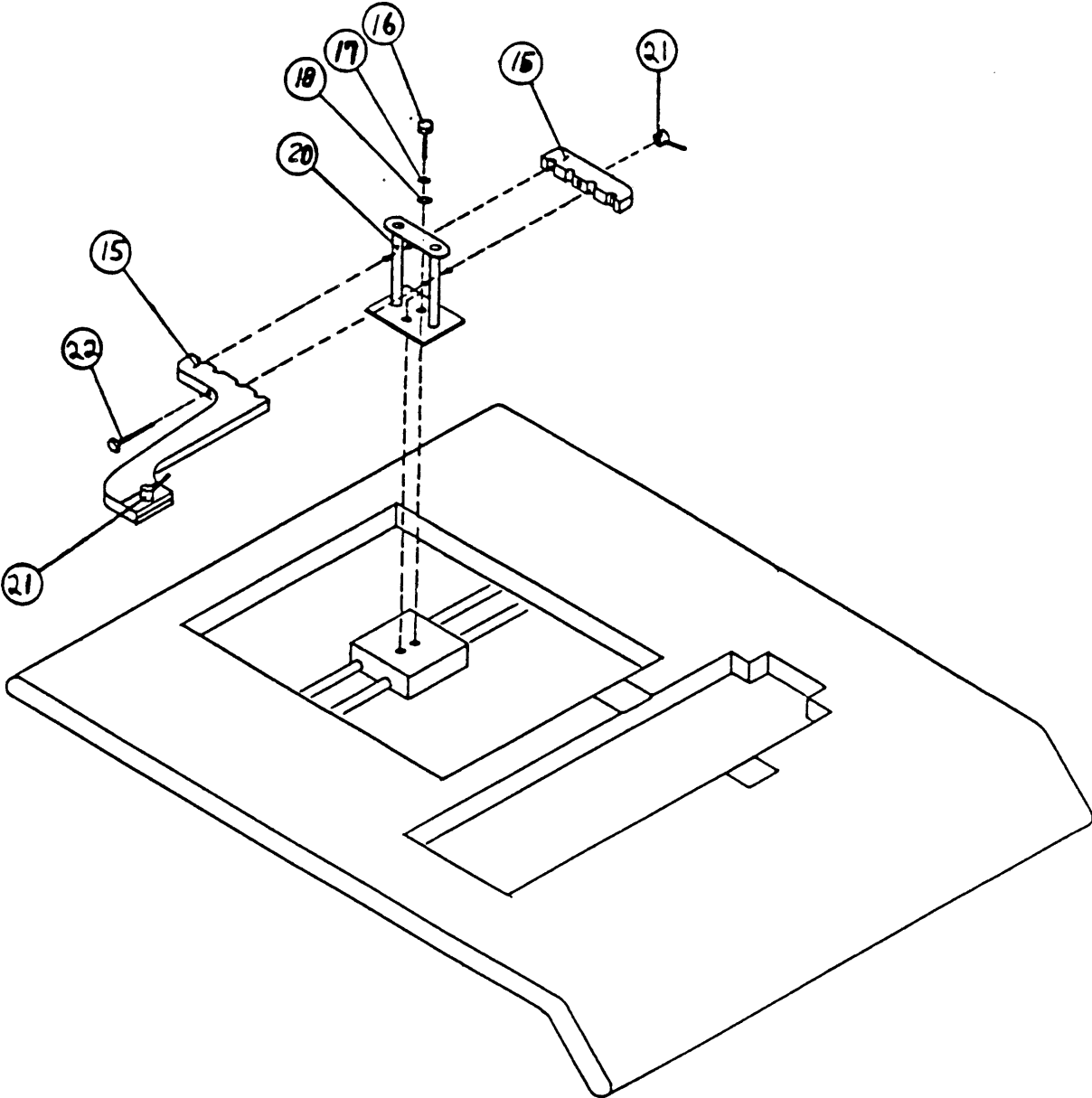



Fig. 7-5: Hoop Arm Assembly Installation



7.1.3. Head Assembly Drawings

ASSEMBLY NAME: Head Assembly Drawings ASSEMBLY FIG. NO.: 7.6  
 7.7  
 7.8  
 7.9

REF.	QTY.	PART NO.	DESCRIPTION
01	1	P514000	M700 Sewing Head Assembly
02	1	P530408	Head Interface Card M700
03	1	P514012	Tension Release Solenoid Rod
04	1	P820350	Heat Shrink Sleeve 3/32"
05	1	P514010	Tension Release Solenoid Assembly
06	1	P514038	Cover, Interface Card
07	2	P840150	Screw, #6-32 x 1/4 Phillips Rd Hd
08	3	P514005	S.W. Motor Hex Standoff
09	1	P312013	S.W. Motor Coupling
10	3	P840071	Screw, #8-32 x 1" Socket Head
11	3	P840508	#8 Internal Tooth Lockwasher
12	3	P840520	#8 Flat Washer
13	1	P514050	StitchWidth Motor Assembly
14	1	P413018	Magnet
15	2	P840147	Screw #6-32 x 3/8 Phillips Rd Hd
16	2	P840509	#6 Split Lockwasher
17	1	P514045	Stitch Width Limit Pickup Assembly
18	1	P514040	PT/NPS Pickup Assembly
19	1	P514030	PT/NPS Sender Assembly
20	1	P517100	Thread Break Tension Assembly M700
21	1	P810080	Counterweight, Head
22	2	P840621	Screw, #10-32 x 3/4 lg. Socket Hd.
23	2	P840410	Screw, #6-32 x 3/8 lg. Pan Head
24	2	P820056	Cable Clip 1/8 dia.

Fig. 7-6: Rear - Head Assembly

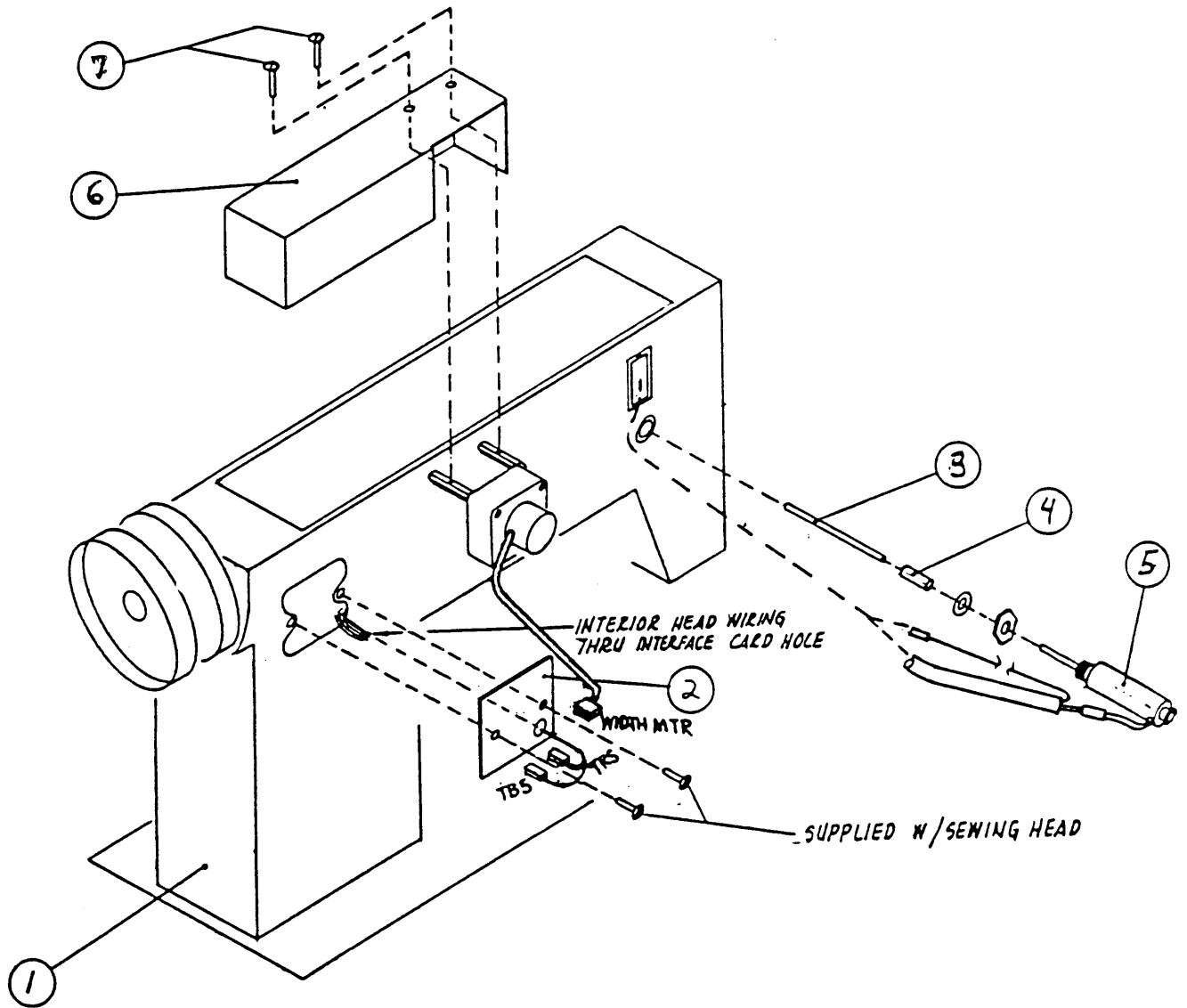

Fig. 7-7: Stitch Width Motor Assembly

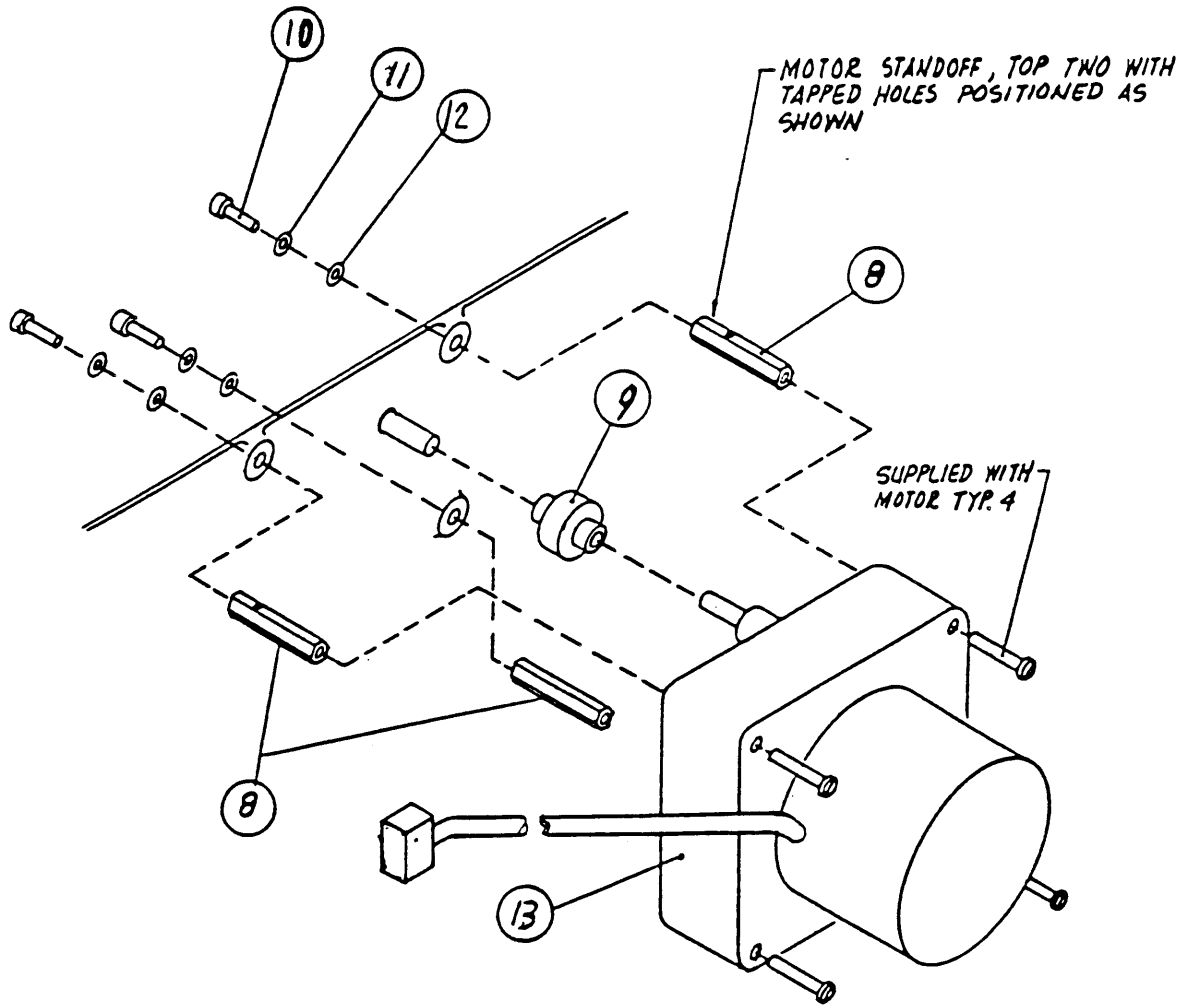

Fig. 7-8: Wire Routing and PT/NPS Sender Installation

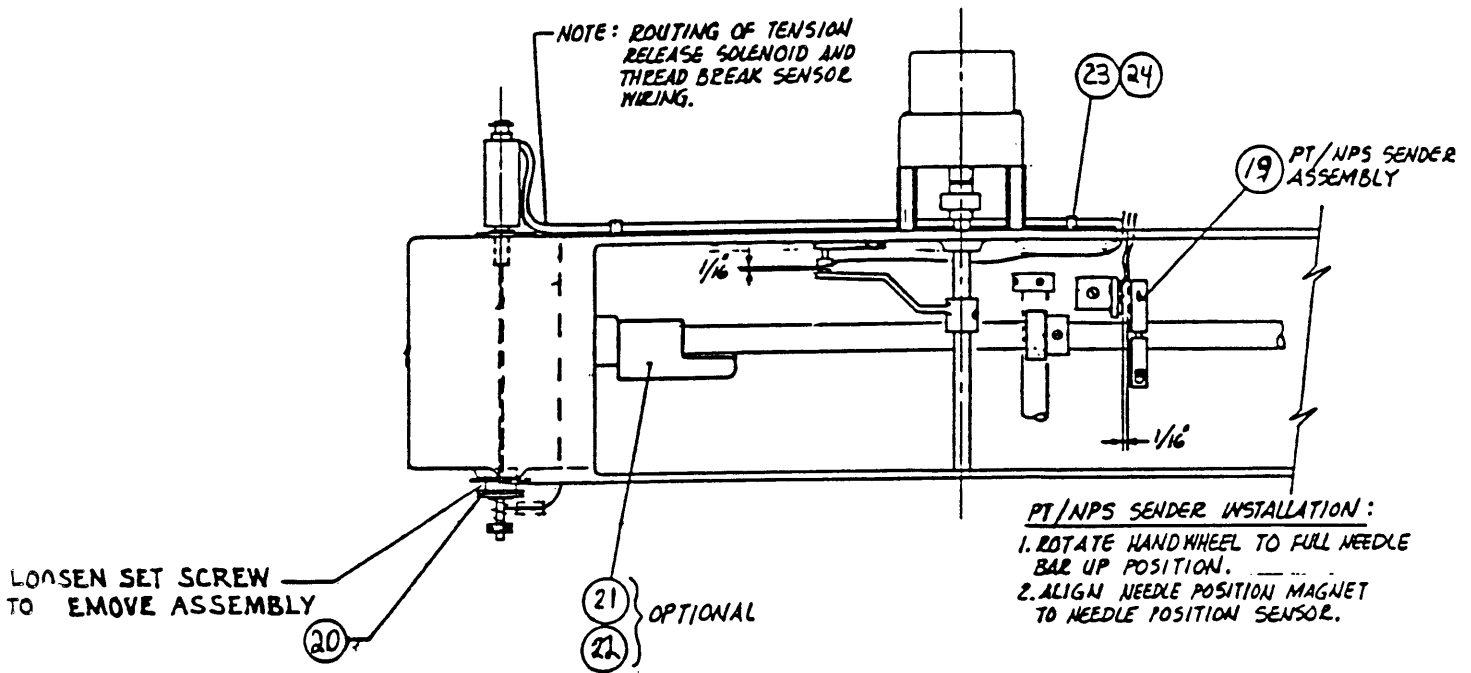
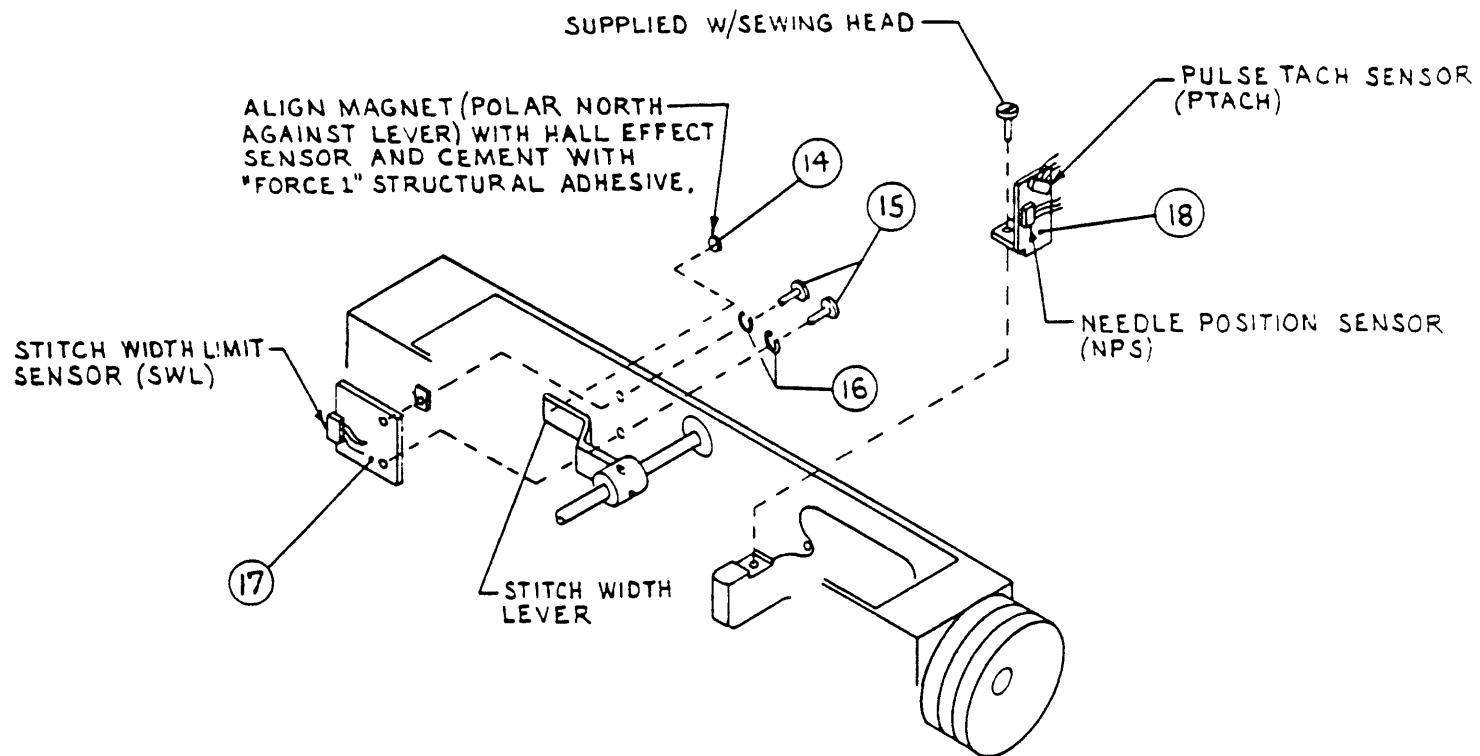

Fig. 7-9: Hall Effect Sensor Installations



#### 7.1.4. Power Transformer Assy.

ASSEMBLY NAME: Power Transformer Assy. ASSEMBLY FIG. NO.: 7.10

REF.	QTY.	PART NO.	DESCRIPTION
01	4	P840197	Screw 1/4-20 x 1/2 Type "F" Hex Hd.
02	1	P820033	Strain Relief Connector
03	1	P520105	Power Cord M700
04	1	P335167	Fuse Holder
05	2	P520066	Axle, Wheel
06	2	P520062	3 x 1 1/4 Durafoam Wheel
07	2	P520064	Locknut, Wheel
08	2	P520103	Standoff #6-32 x 3/8 Hex Internal Thrd
09	2	P840720	Hex Nut, #6-32
10	2	P840205	Screw, #8-32 x 5/8 Lg., Type "F" Hex Hd
11	2	P530519	Market, Terminal Strip
12	1	P530510	Terminal Strip, 12 Circuit
13	2	P520107	Self-Clinch Stud #6-32 x 7/8"
14	4	P840511	#6 Lockwasher, Internal Tooth
15	1	P530500	Transformer Assembly

Fig. 7-10: Frame - Lower Left Corner

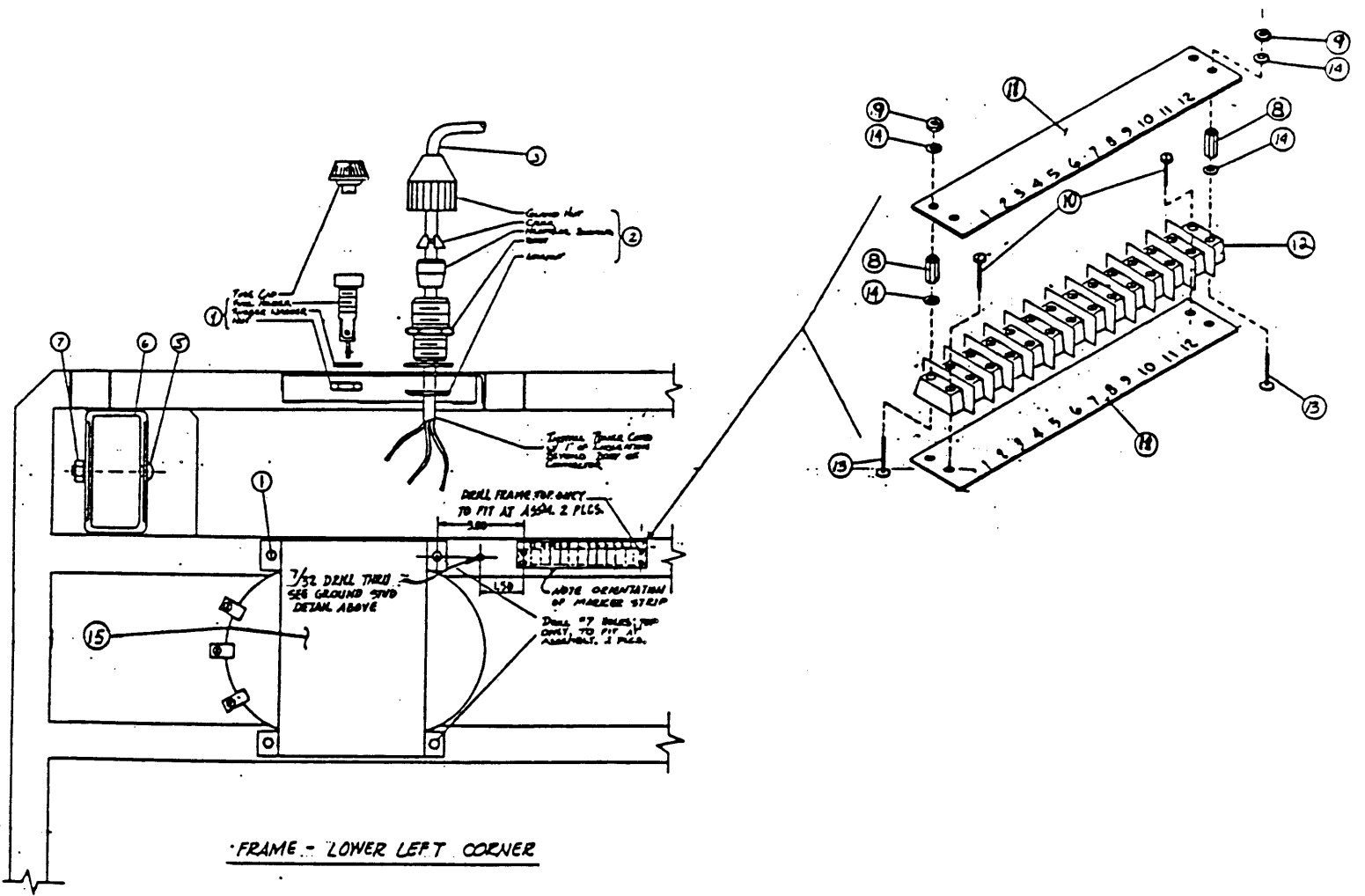



7.1.5. Frame Assy-Front View

ASSEMBLY NAME: Frame Assy-Front View

ASSEMBLY FIG. NO.: 7.11

7.12

7.13

REF.	QTY.	PART NO.	DESCRIPTION
01	2	P520068	Leveling Foot
02	1	P530412	Diagnostic Circuit Board
03	1	P530025	Card Cage Assembly
04	3	P840189	Screw, Mach., #6-32 x 3/4 Slotted Pan Hd
05	3	P840509	#6 Lockwasher, Split
06	3	P840720	#6-32 Hex Nut
07	3	P840510	#6 Flat Washer
08	4	P840417	Screw, #8-32 x 3/16 Slotted Pan Head

Fig. 7-11: Power Control Cover, Diagnostic Board & Leveling Feet Installation

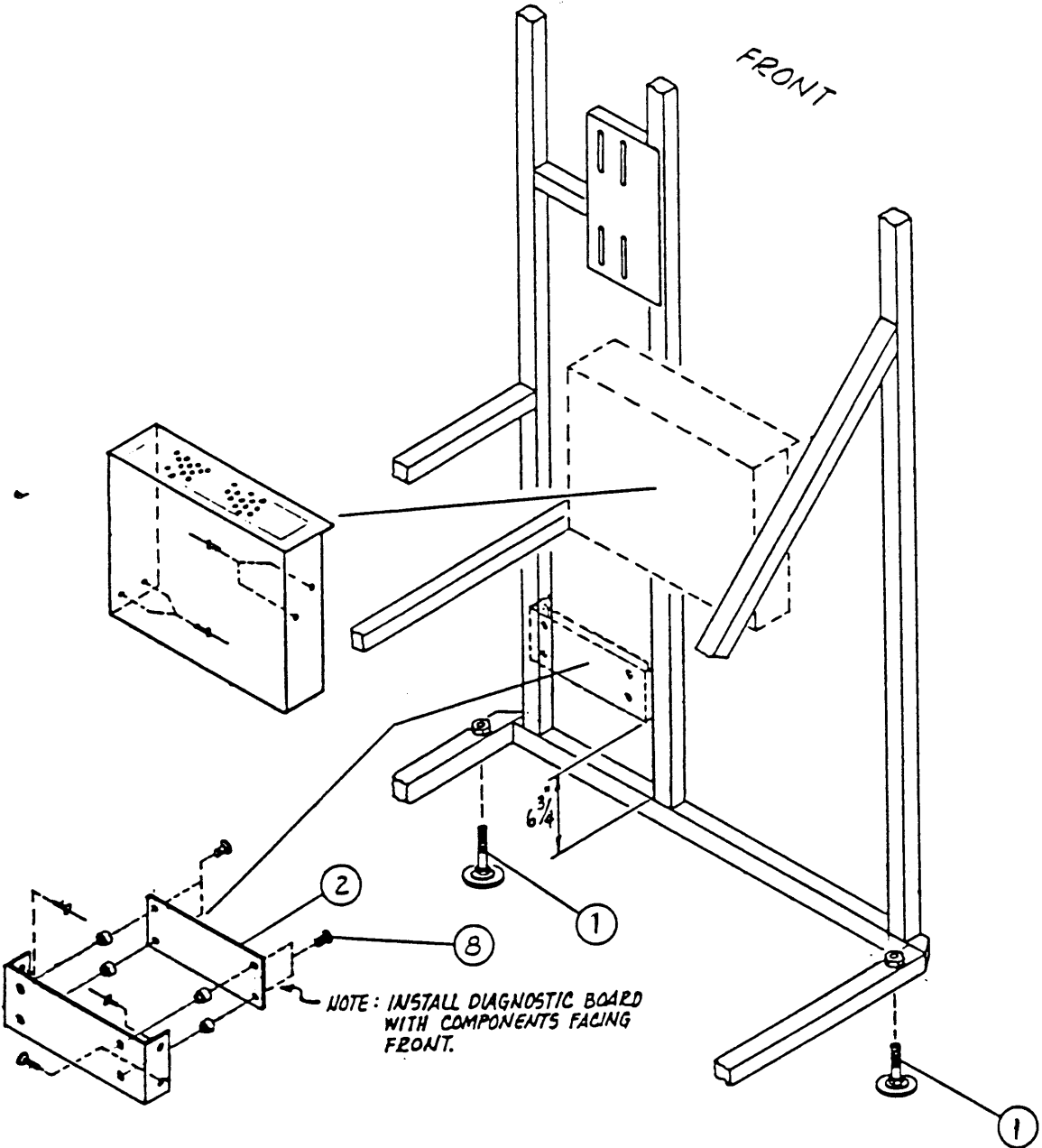

Fig. 7-12: Ribbon Cable Guide & Card Cage Shield/Enclosure Installation

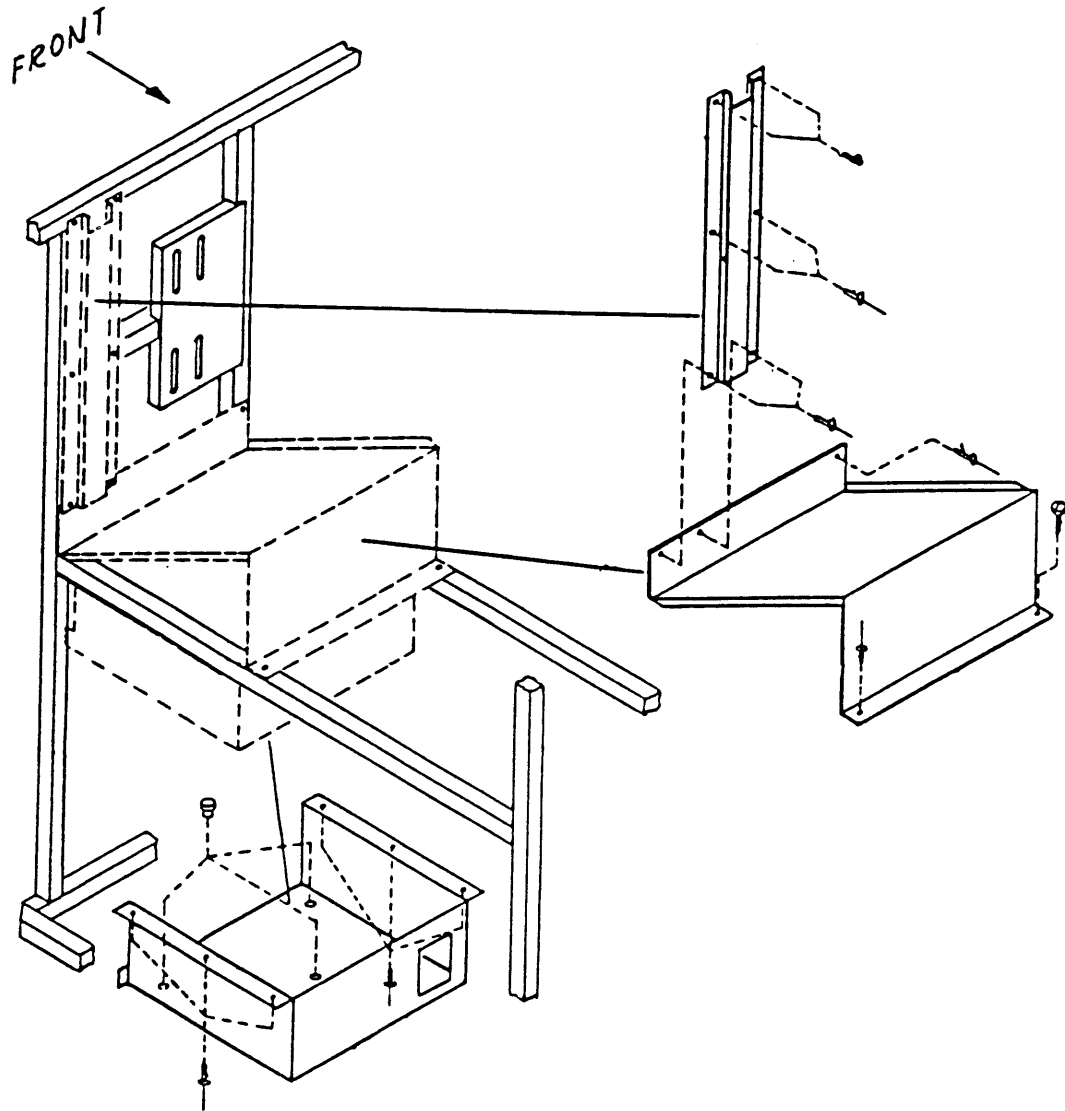
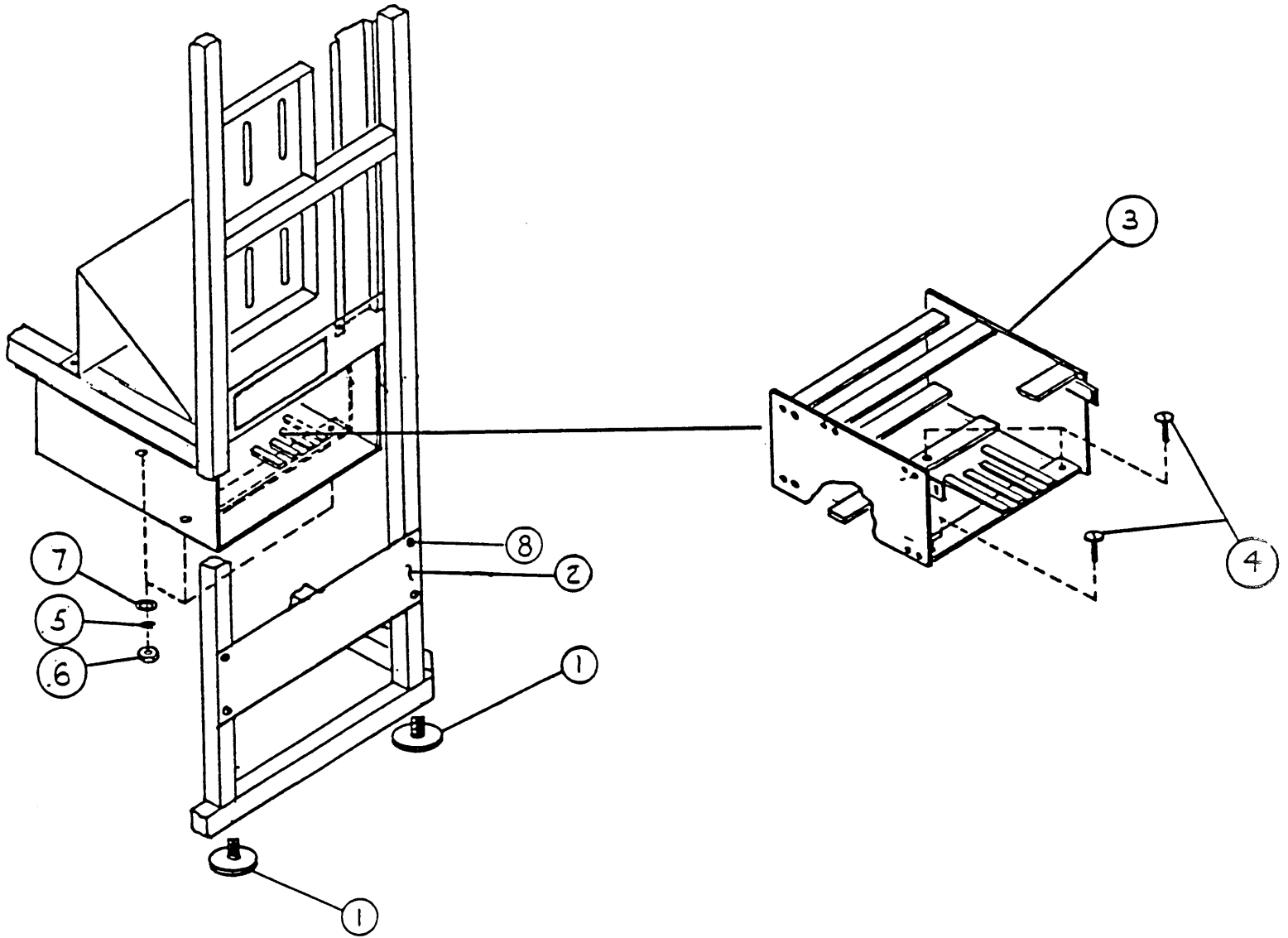

Fig. 7-13: Card Cage & Decal Installation



### 7.1.6. Pantograph Assembly

ASSEMBLY NAME: Pantograph Assembly

ASSEMBLY FIG. NO.: 7.14

7.15

7.16

7.17

REF.	QTY.	PART NO.	DESCRIPTION
01	1	P520400	Pantograph Assembly
02	3	P840141	Screw, 1/4-20 x 1 1/2 Slotted Flt Hd.
03	3	P520509	Neoprene Well-Nut, 1/4-20 Thread
04	3	P520406	T-Nut, 1/4-20 x 7/16 Plain Slab Base
05	3	P520408	Rubber Grommet Z-148
06	1	P520072	Head Locking Screw
07	1	P520074	Head Locking Screw Spring
08	6	P840540	1/4" Flatwasher, Plated
09	5	P840915	Rubber Grommet Z-399
10	1	P840710	1/4-20 Hex Nut
11	1	P840785	4 Prong Black Fingernut
12	1	P520002	Table Top, M700
13	6'	9P520001	7/8" wide x 1/2" thick Adhesive Tape Neoprene Strip (lengths noted on dwg)
14	4	P840057	Screw, 1/4-20 x 2 1/4 Socket Head
15	1	P530300	DC Motor Assembly
16	4	P840603	Bolt, 5/16-18 x 1 Hex Head
17	8	P840561	5/16 Flatwasher
18	4	P840582	5/16 Lockwasher, Split
19	4	P840707	5/16-18 Hex Nut
20	8	P840203	Screw, #8-32 x 1/2 Type F Hex Head
21	1	P530414	CPU Power Supply Cover
22	1	P530400	CPU Power Supply Assembly
23	1	P520053	Drip Pan
24	4	P840410	Screw, #6-32 x 3/8 Slotted Pan Head
25	1	P520055	Pantograph Pan
26	1	P520054	Drip Pan Bracket

Fig. 7-14: Pantograph & Head Locking Screw Assy. Installation

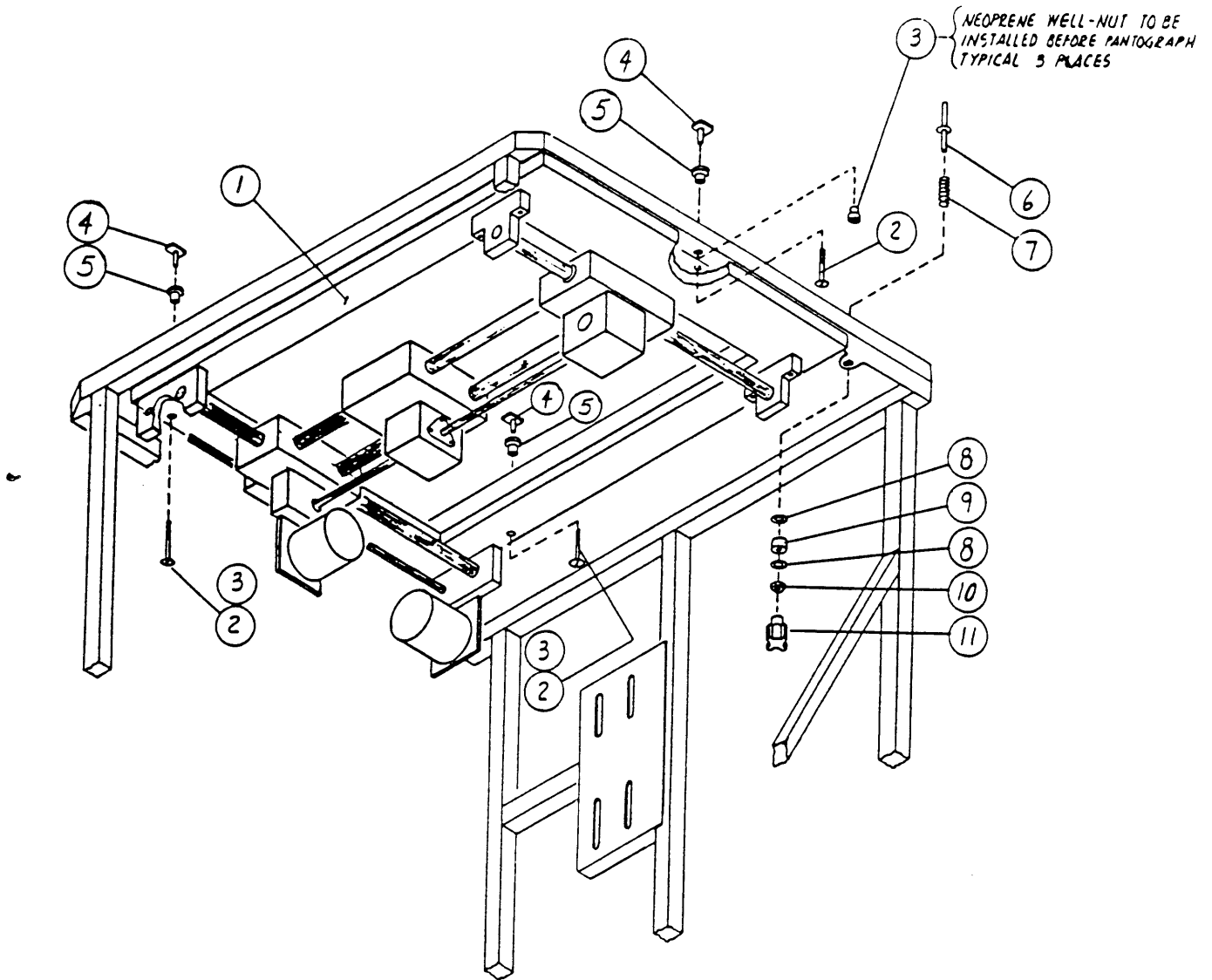

Fig. 7-15: Table Top Installation

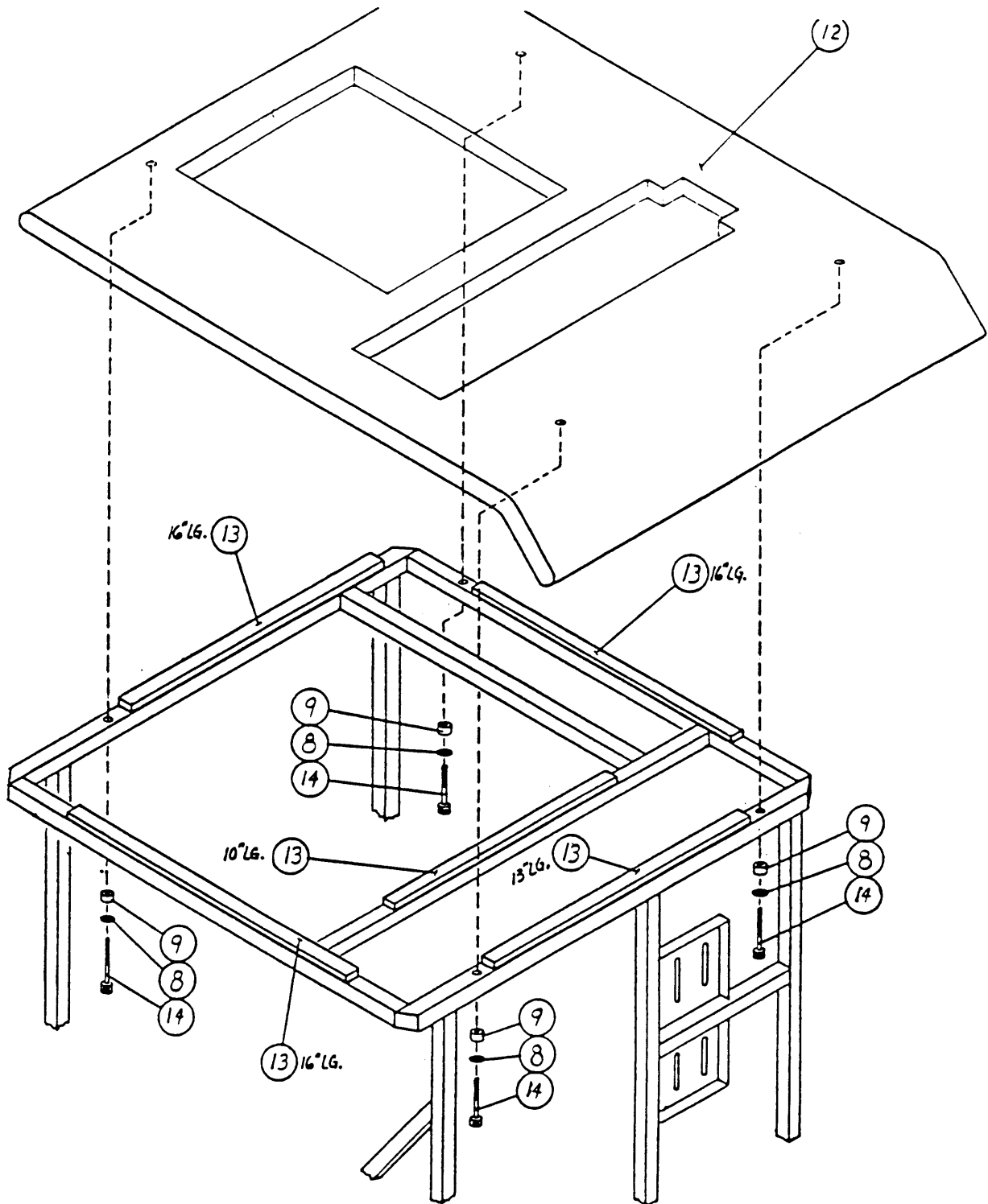

Fig. 7-16: Drip Pan Installation

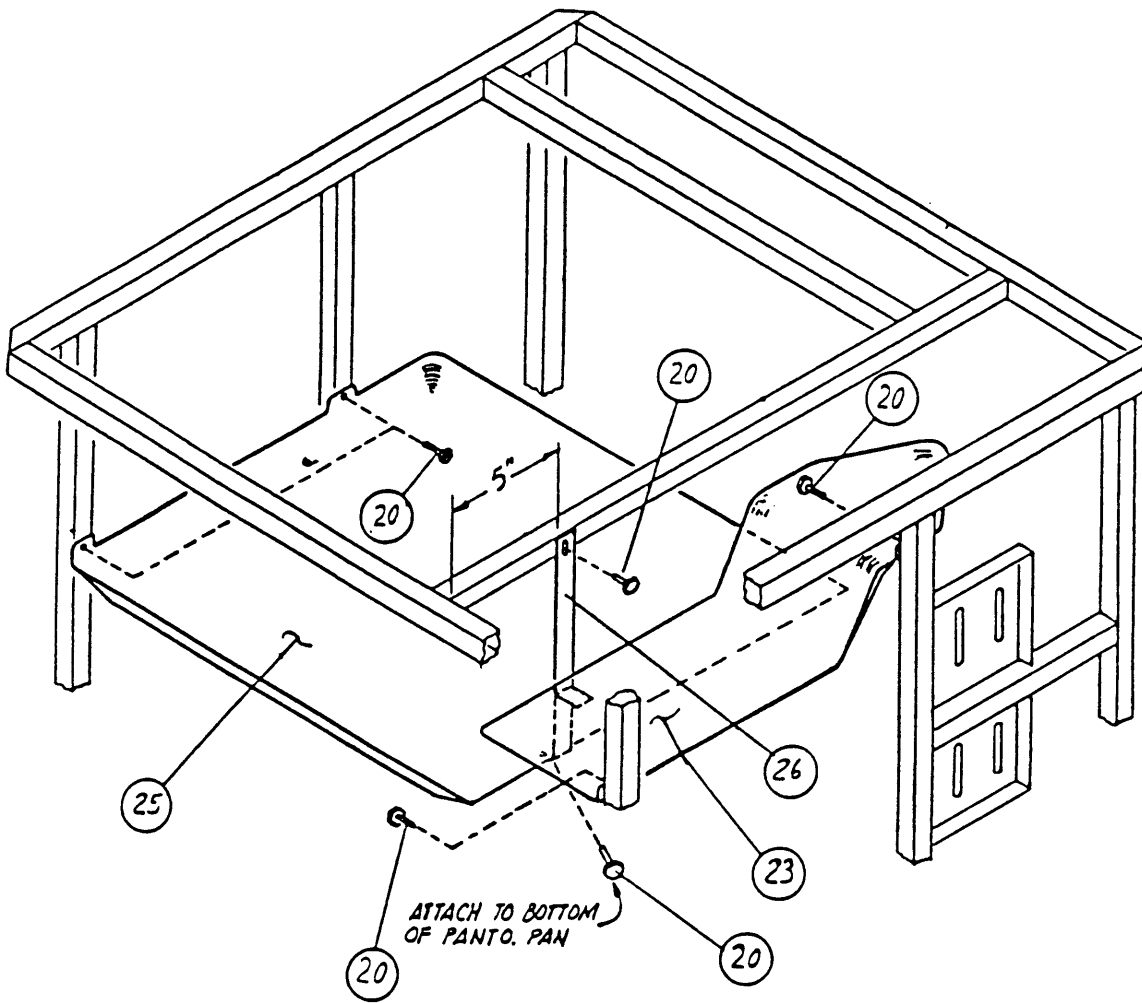
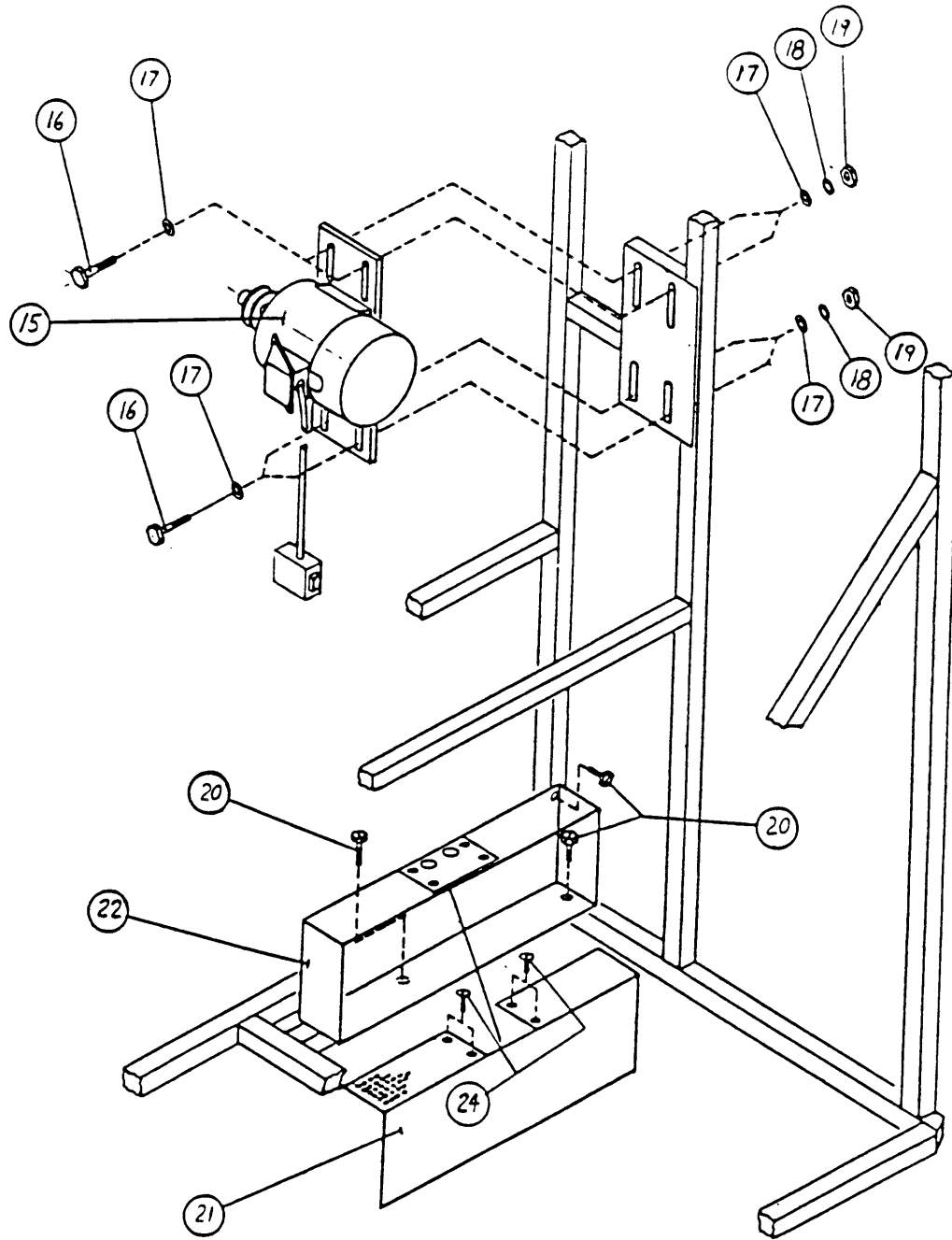



Fig. 7-17: CPU Power Supply & DC Motor Installation



### 7.1.7. Electrical Wiring

ASSEMBLY NAME: Electrical Wiring

ASSEMBLY FIG. NO.: 7.18  
7.19

REF.	QTY	PART NO.	DESCRIPTION
01	1	P530750	Main Frame Harness
02	1	P530755	Pantograph Limit Harness
03	1	P530710	Ribbon Cable, Head Interface
04	1	P530715	Display Power Harness
05	1	P530730	Ribbon Cable, PE-CLC
06	1	P530725	Ribbon Cable, Console - CLC
07	1	P530503	Diode Harness

Fig. 7-18: Frame Electrical Wiring

- NOTES:  
 2. X-AXIS STEPPER MOTOR, TO J6 CONNECTOR ON POWER ELECTRONICS BOARD.  
 3. Y-AXIS STEPPER MOTOR, TO J7 CONNECTOR ON POWER ELECTRONICS BOARD.

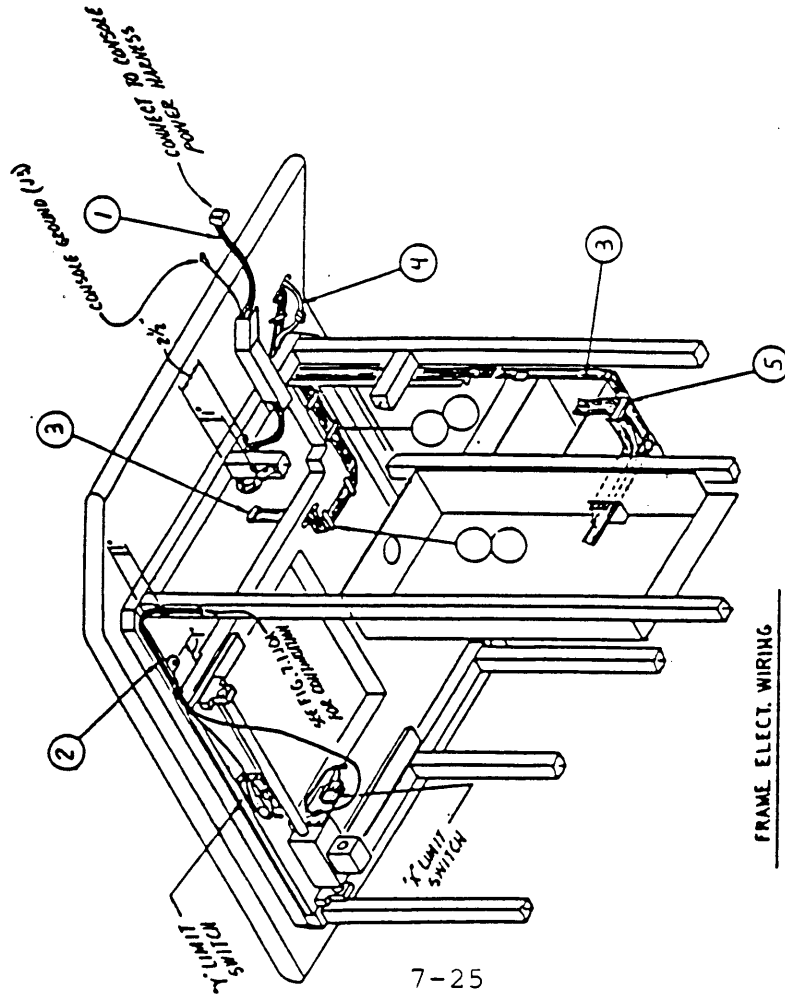
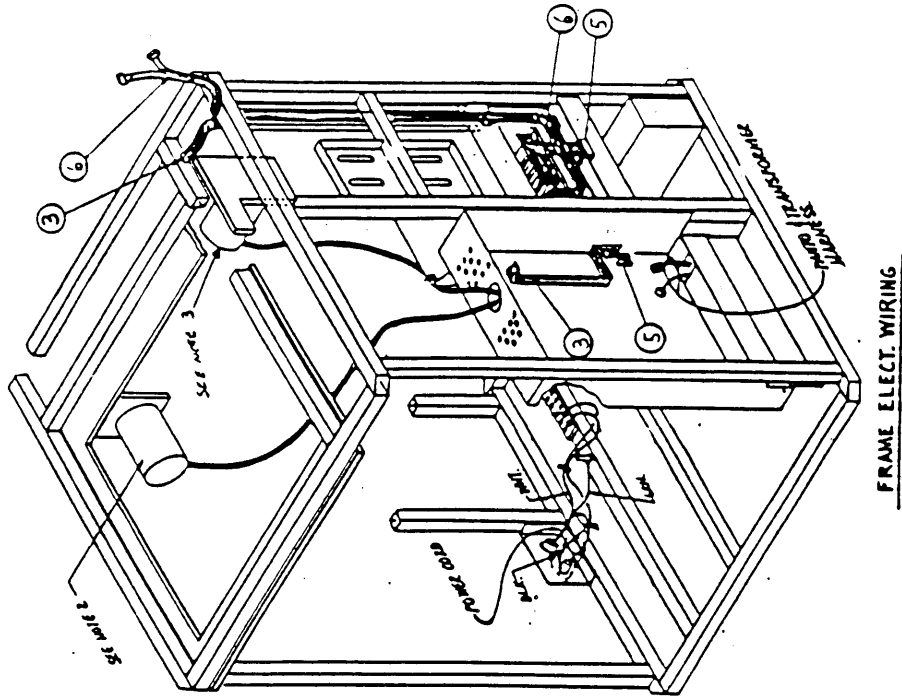

FIG: 7.1.10C

Fig. 7-19: Frame Electrical Wiring

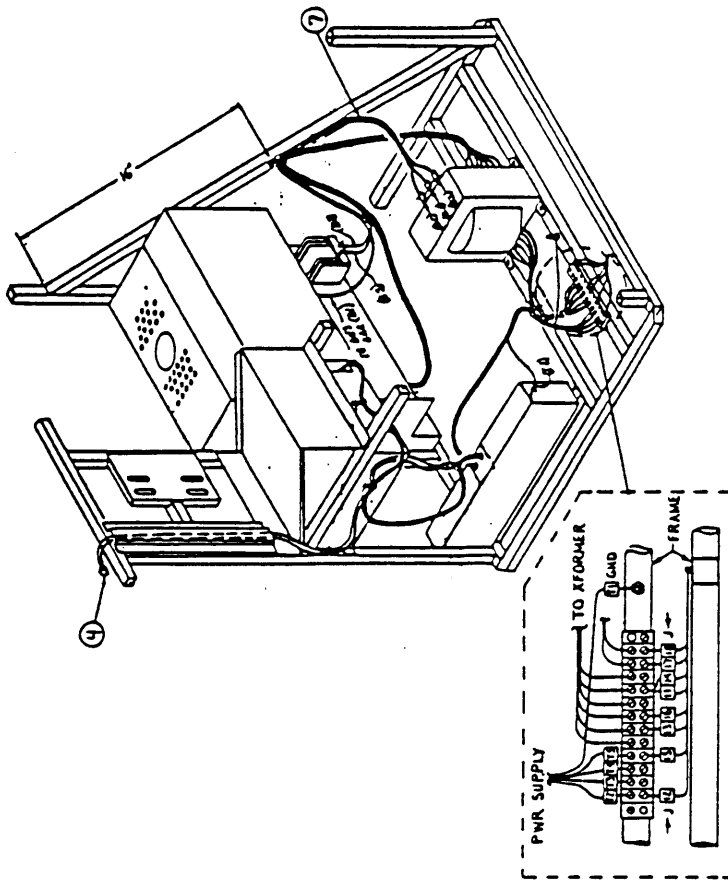
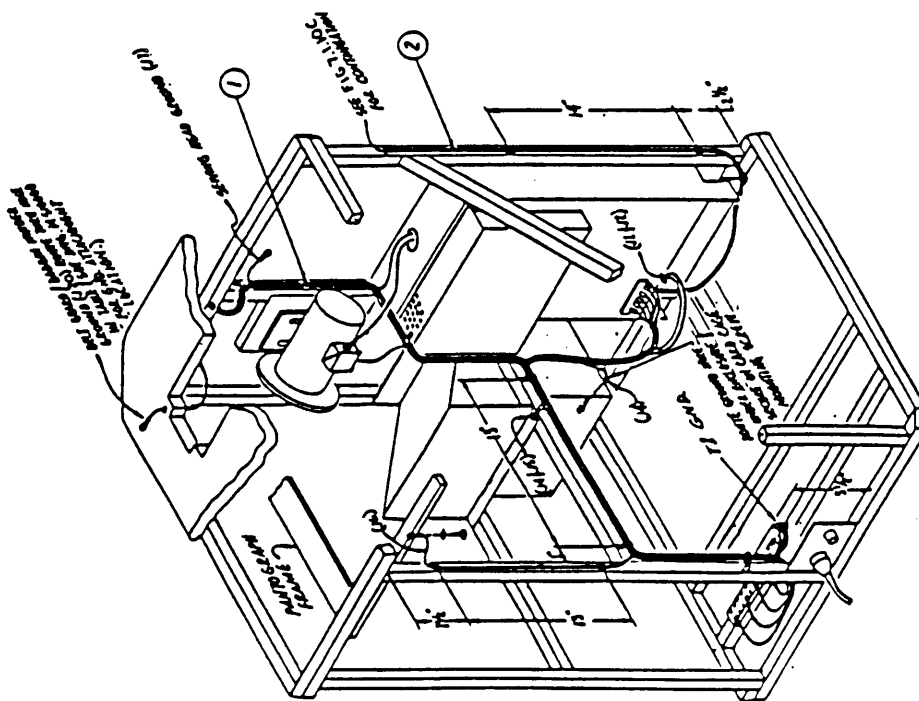

FIG. 7.1.100



FRAME ELECT. WIRING

**7.1.8. Control Console Assy.**

ASSEMBLY NAME: Control Console Assy.

ASSEMBLY FIG. NO.: 7.20

7.21

REF.	QTY.	PART NO.	DESCRIPTION
01	1	P530100	Control Console Assembly
02	1	P520012	Switch, Illuminated Power
03	1	P520016	Safety Switch DPST
04	1	P520018	Switch, Stop
05	1	P520020	Red Button, Stop Switch
06	1	P840562	Washer, Flat 1/2" I.D. x 1" O.D. x .032 thick, Steel
07	1	P530715	Display Power Harness
08	1	P530125	Tape Drive M700
09	1	P530108	Keyboard, M700
10	2	P520029	Mounting Bracket, Keyboard
11	1	P330440	Display
12	1	P530103	Filter, Display
13	1	P630139	Bezel, Display
14	1	P530735	Ribbon Cable, Keyboard to Display
15	4	P840510	#6 Flatwasher
16	1	P530785	Console Stop Switch Harness
17	8	P840720	#6-32 Hex Nut
18	16	P840511	#6 Lockwasher, Internal Tooth
19	2	P520081	Screw, #6-32 x 5/8 Phillips Decorative Head
20	5	P840410	Screw, #6-32 x 3/8 Slotted Pan Head
21	4	P530132	Standoff, #6-32 x 1/2 Internal Thread
22	1	P530795	Console Power Harness
23	13"	9P891300	22 Ga. Wire, Green

Fig. 7-20: Control Console Assembly

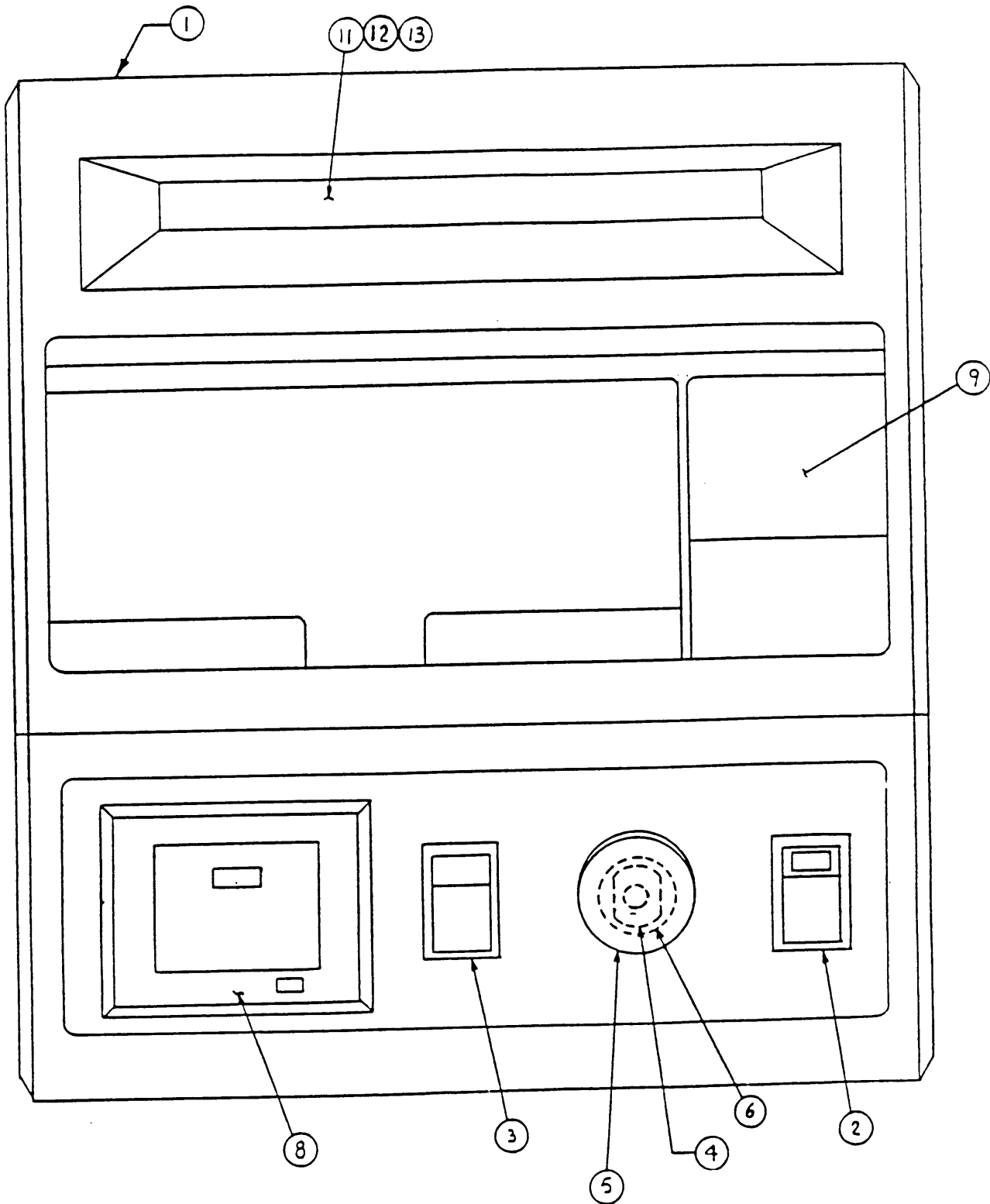
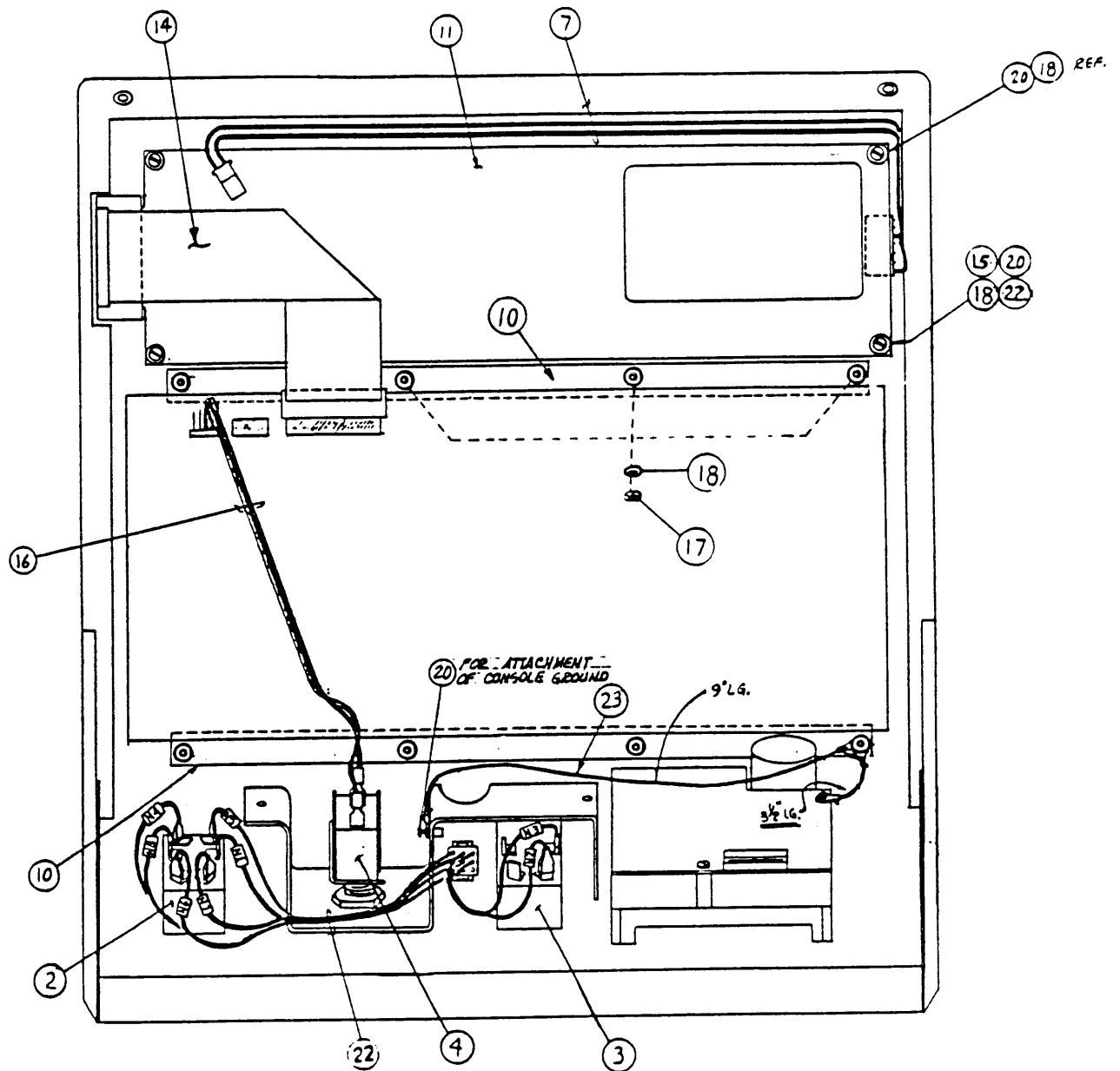

Fig. 7-21: Control Console Assembly



7.1.9. Power Control Assembly

ASSEMBLY NAME: Power Control Assembly ASSEMBLY FIG. NO.: 7.22  
 7.23  
 7.24

REF.	QTY.	PART NO.	DESCRIPTION
01	1	P53020	Power Control Assembly
02	1	P530775	KBIC Board with Harness Assembly
03	1	P530117	P.E. Board
04	1	P530119	M.C. Board
05	2	P530221	1.5 Ohm 50 Watt Power Resistor
06	4	P530217	1.2 Ohm 100 Watt Power Resistor
07	1	P530220	10 Ohm 25 Watt Power Resistor
08	2	P530120	54,000 UF 20 VDC Capacitor
09	1	P530780	Motor Control - P.E. Harness
10	1	P530765	Power Control Harness
11	2	P330448	Line Filter 120/240 volt at 5 Amp.
12	1	P530340	Diode Heat Sink Assembly
13	4	P530227	Teflon Insulator
14	1	P530790	Resistor Harness
15	3	P334167	Fuse Holder
16	6	P840404	Screw #4-40 x 3/8 Slotted Pan Hd.
17	6	P840505	#4 Lockwasher, Internal Tooth
18	6	P840715	#4-40 Hex Nut
19	6	P840520	#8 Flat Washer
20	7	P840523	#8 Lockwasher Split
21	15	P840732	#8-32 Hex Nut, Small Pattern
22	8	P840169	Sheet Metal Screw #6 x 1/2 Type A Slotted Pan Head
23	8	P840167	Sheet Metal Screw #6 x 1/2 Type A Slotted Pan Head
24	30	P840511	#6 Lockwasher, Internal Tooth
25	10	P840410	Screw #6-32 x 3/8 Slotted Pan Head
26	10	P840720	#6-32 Hex Nut
27	10	P530213	Hex Standoff #6-32 x 1 Male - Female
28	17	P840420	Screw #10-32 x 3/8 Slotted Pan Head
29	17	P840576	#10 Lockwasher, Internal Tooth, Bronze
30	15	P840732	#8-32 Hex Nut, Small Pattern
31	8	P840450	Screw #8-32 x 3/8 Slotted Pan Head
32	9	P840508	#8 Lockwasher, Internal Tooth



Fig. 7-22: Power Control Assembly Rear View A

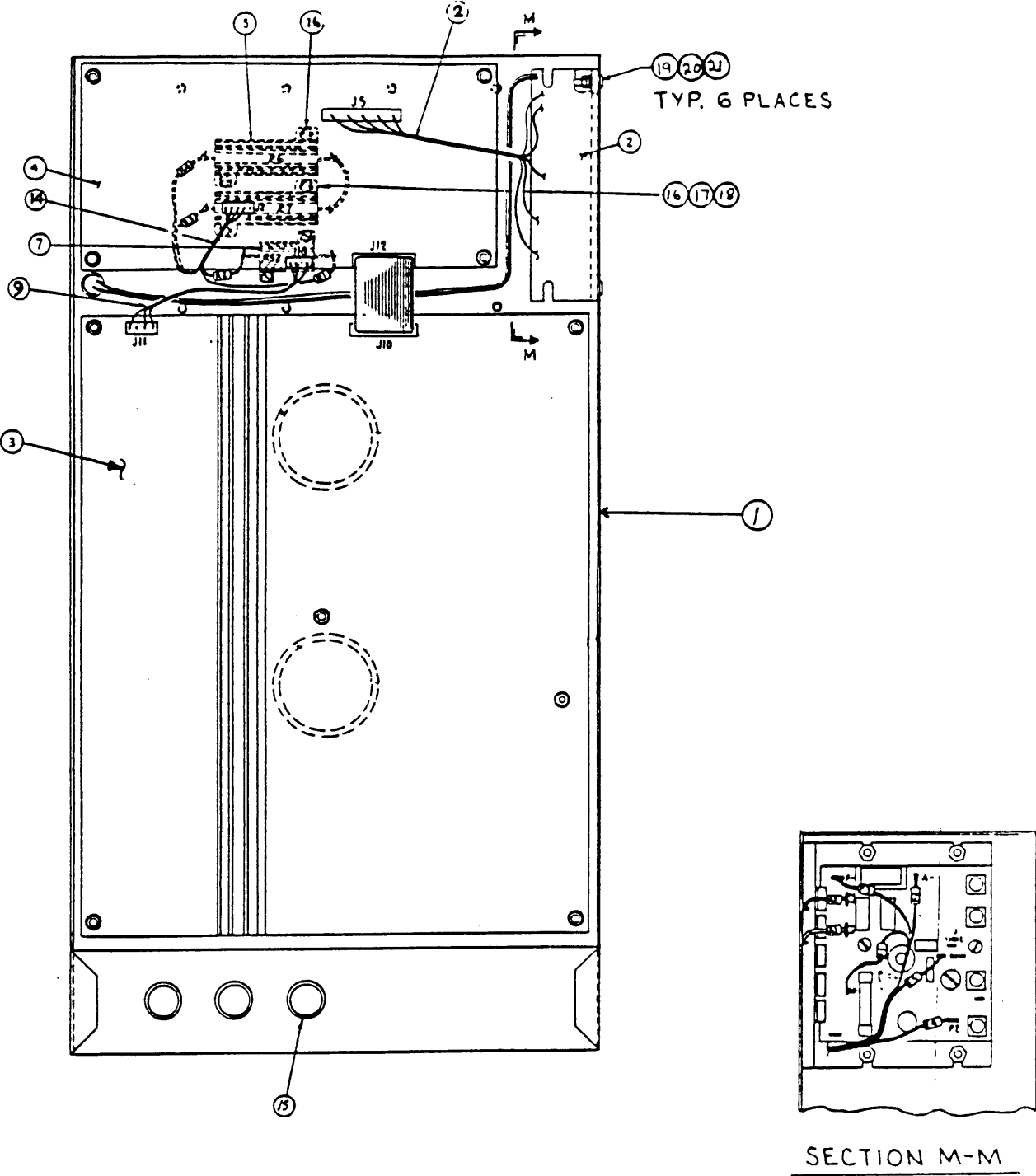

Fig. 7-23: Power Control Assembly Rear View B

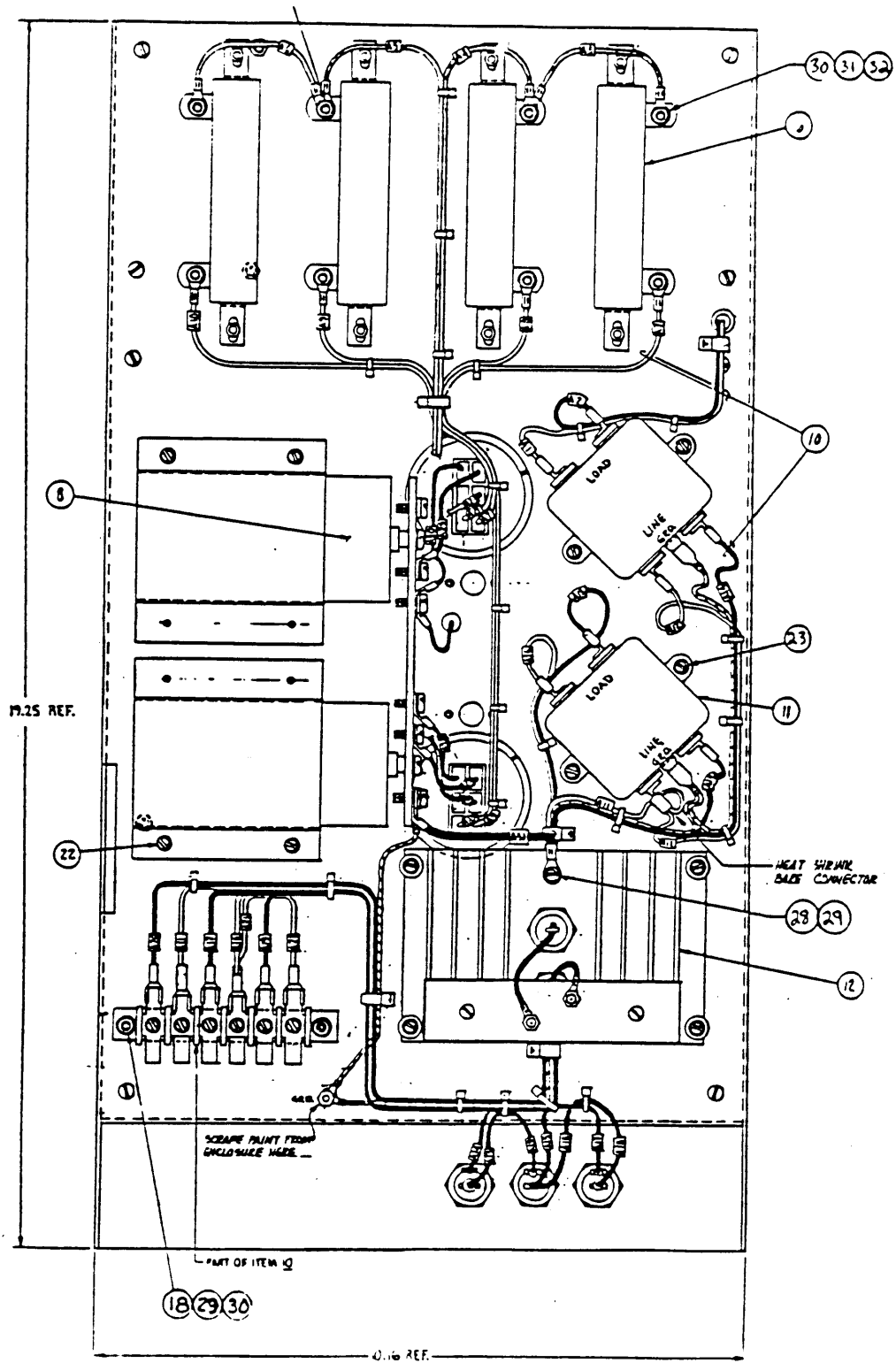
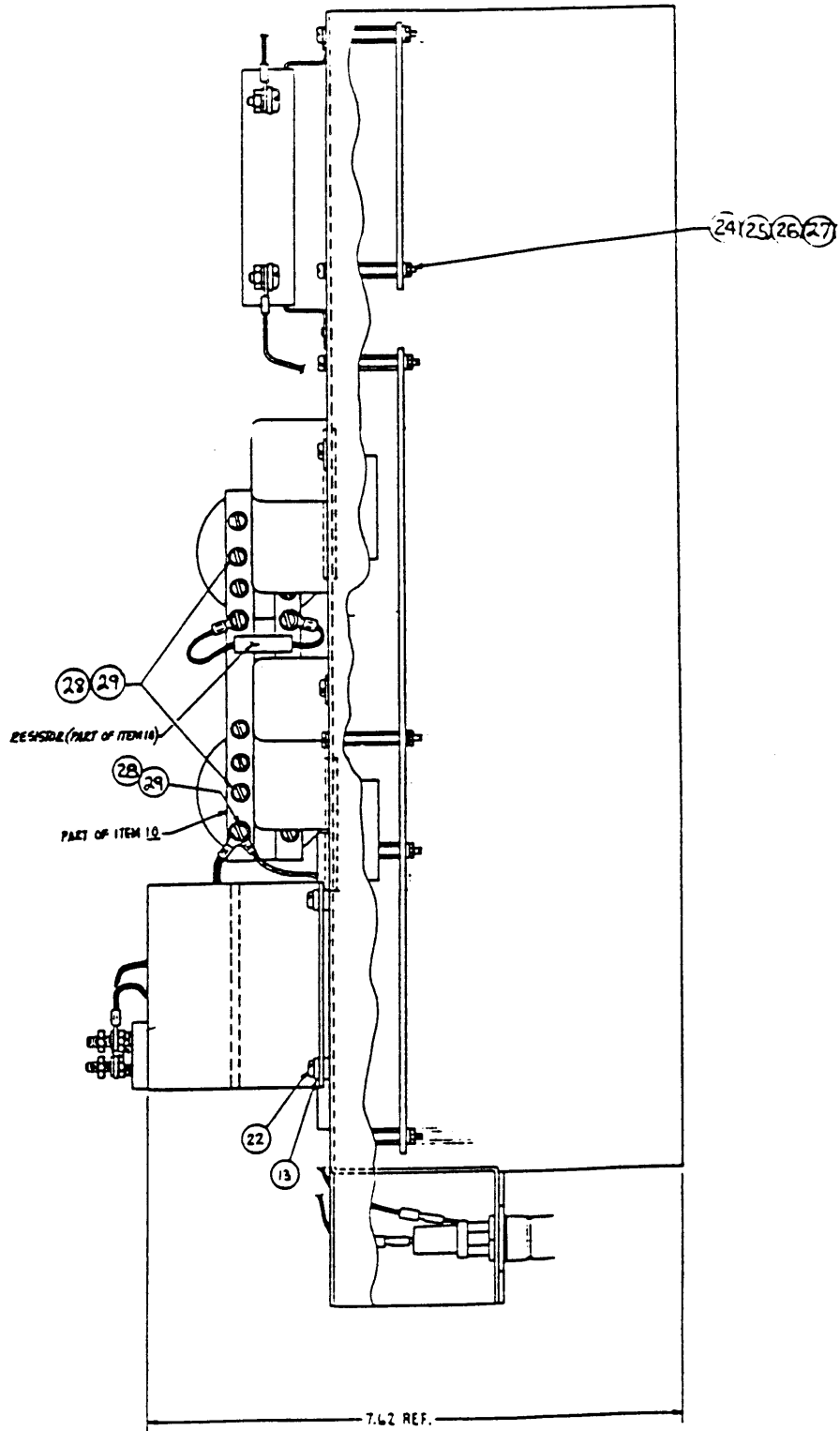

Fig. 7-24: Power Control Assembly Rear View C



## 7.2. M700 Sewing Head

### 7.2.1. Main Frame and cover

ASSEMBLY NAME: M700 SEWING HEAD:  
Main Frame & cover

ASSEMBLY FIG. NO.: 7.25  
ADDENDUM

REF.	QTY.	PART NO.	DESCRIPTION
7101	1	P517101	Arm Bed
7102	1	P517102	Top Cover
103	2	P312103	Screw
7104	1	P517104	Face Plate
105	1	P312105	Screw
7106	1	P517106	Arm Side Cover (Large)
107	2	P312107	Screw
7108	1	P517108	Arm Side Cover (Small)
109	2	P312109	Screw
7110	1	P517110	Needle Plate
111	1	P312111	Thread Guide (4 hole)
112	1	P312112	Thread Guide (2 hole)
113	1	P312113	Three Hole Thread Eyelet
114	1	P312114	Screw
115	2	P312115	Arm Thread Guide (Upper & Lower)
116	2	P312116	Screw
117	1	P312117	Tension Post Thread Guide
118	1	P312118	Screw
119	1	P312119	Tension Post Rocket
120	1	P312120	Screw
121	1	P312121	Tension Post
122	1	P312122	Screw
123	1	P312123	Take Up Spring
124	2	P312124	Tension Disk
125	1	P312125	Tension Release Washer
126	1	P312126	Tension Spring
7127	1	P517127	Tension Nut
128	1	P312128	Reservoir (Front) Oil Wick
129	1	P312129	Oil Pad
130	1	P312130	Reservoir (Front) Cover Plate
131	2	P312131	Screw
132	1	P312132	Oil Reservoir (Rear)
133	2	P312133	Screw
134	1	P312134	Oil Wick
135	1	P312135	Oil Pad
136	1	P312136	Cover Plate
137	2	P312137	Screw
7138	1	P517138	Washer for Tension Nut
7139	1	P517139	Needle Plate Set Screw

Fig. 7-25: Main Frame and Misc. Cover Components

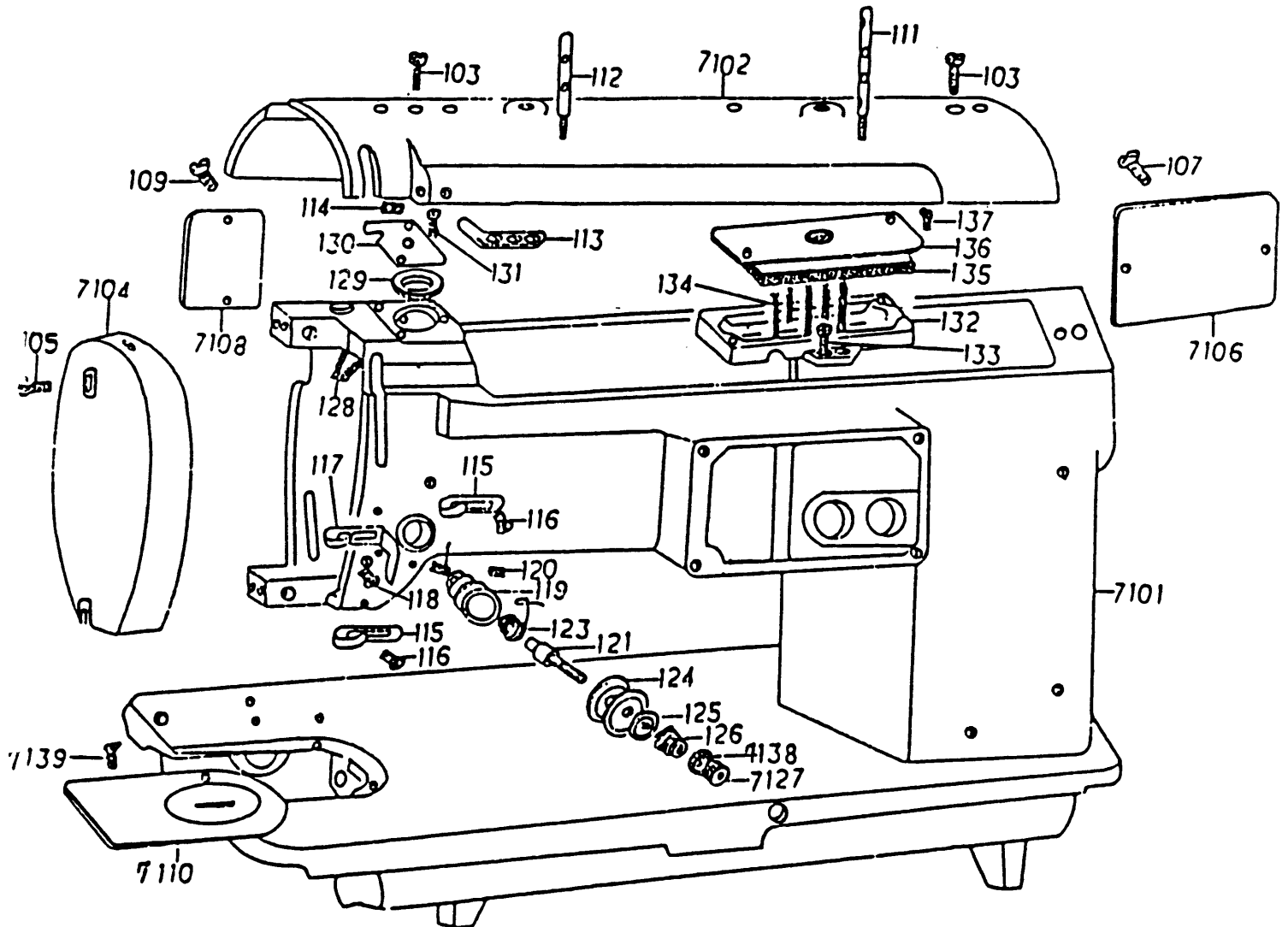

## 7.2.2. Needle Bar & Hook Drive

ASSEMBLY NAME: M700 SEWING HEAD: ASSEMBLY FIG. NO.: 7.26  
Needle Bar & Hook Drive ADDENDUM  
Shaft Components

201	1	P312201	Needle Bar Frame
202	1	P312202	Hinge Pin
203	1	P312203	Screw
204	1	P312204	Needle Bar
205	1	P312205	Needle Bar Connecting Stud
206	1	P312206	Bushing
207	1	P312207	Washer
208	1	P312208	Screw
209	1	P312209	Needle Bar Set Screw
210	1	P312210	Needle Bar Connecting Link
211	1	P312211	Screw
213	1	P312213	Needle Bar Frame Guide Pin
214	1	P312214	Screw
215	1	P312215	Needle
216	1	P312216	Needle Set Screw
217	1	P312217	Take-Up Lever Link Hinge Pin
218	1	P312218	Screw
219	1	P312219	Take-Up Lever with Cam
220	1	P312220	Needle Bar Crank
221	1	P312221	Screw (Large)
222	1	P312222	Screw (Small)
223	1	P312223	Counterweight
224	1	P312224	Screw (Large)
225	1	P312225	Screw (Small)
226	1	P312226	Needle Bar Connecting Link Guide Plate
227	1	P312227	Screw (Upper)
228	1	P312228	Screw (Lower)
229	1	P312229	Arm Shaft
230	1	P312230	Bushing (Front)
231	1	P312231	Screw
232	1	P312232	Arm Shaft Collar
233	2	P312233	Screw
234	1	P312234	Need Vibration Pinion (Spiral)
235	2	P312235	Screw
236	1	P312236	Arm Shaft (Horizontal) Level Gear
237	2	P312237	Screw
238	1	P312238	Arm Shaft Bushing (Rear)
239	2	P312239	Screw
7240	1	P517240	Handwheel
241	2	P312241	Screw
242	1	P312242	Positioning Screw
243	1	P312243	Gear and Pinion Case
244	1	P312244	Screw
245	1	P312245	Pinion
246	1	P312246	Screw
247	1	P312247	Upright Shaft
248	1	P312248	Bushing (Upper)
249	1	P312249	Screw
250	1	P312250	Bushing (Lower)

251	1	P312251	Screw
252	1	P312252	Miter Gear
253	2	P312253	Screw
254	1	P312254	Miter Gear Case
255	1	P312255	Screw
256	1	P312256	Oil Plug Screw
257	1	P312257	Hook Drive Shaft
258	1	P312258	Miter Gear (Ring)
259	1	P312259	Screw
260	1	P312260	Hook Drive Shaft Bushing (Right)
261	1	P312261	Screw
262	1	P312262	Hook Drive Shaft Thrust Collar
263	2	P312263	Screw
264	1	P312264	Hook Drive Shaft Bushing (Left)
265	1	P312265	Screw
266	1	P312266	Hook Drive Shaft Helical Gear (Right)
267	2	P312267	Screw
268	1	P312268	Helical Gear (Left)
269	2	P312269	Screw
7270	1	P517270	Helical Gear Cover
271	1	P312271	Screw
272	1	P312272	Hook Shaft
273	1	P312273	Bushing (Front)
274	1	P312274	Screw
275	1	P312275	Hook Shaft Thrust Collar
276	2	P312276	Screw
277	1	P312277	Hook Shaft Bushing (Rear)
278	1	P312278	Screw
279	1	P312279	Hook
280	3	P312280	Screw
281	1	312281	Bobbin Case Position Finger
282	1	P312282	Screw
283	1	P312283	Bobbin
284	1	P312284	Bobbin Case
7285	1	P517285	Needle Bar Thread Guide

Fig. 7-26: Needle Bar and Hook Drive Shaft Components

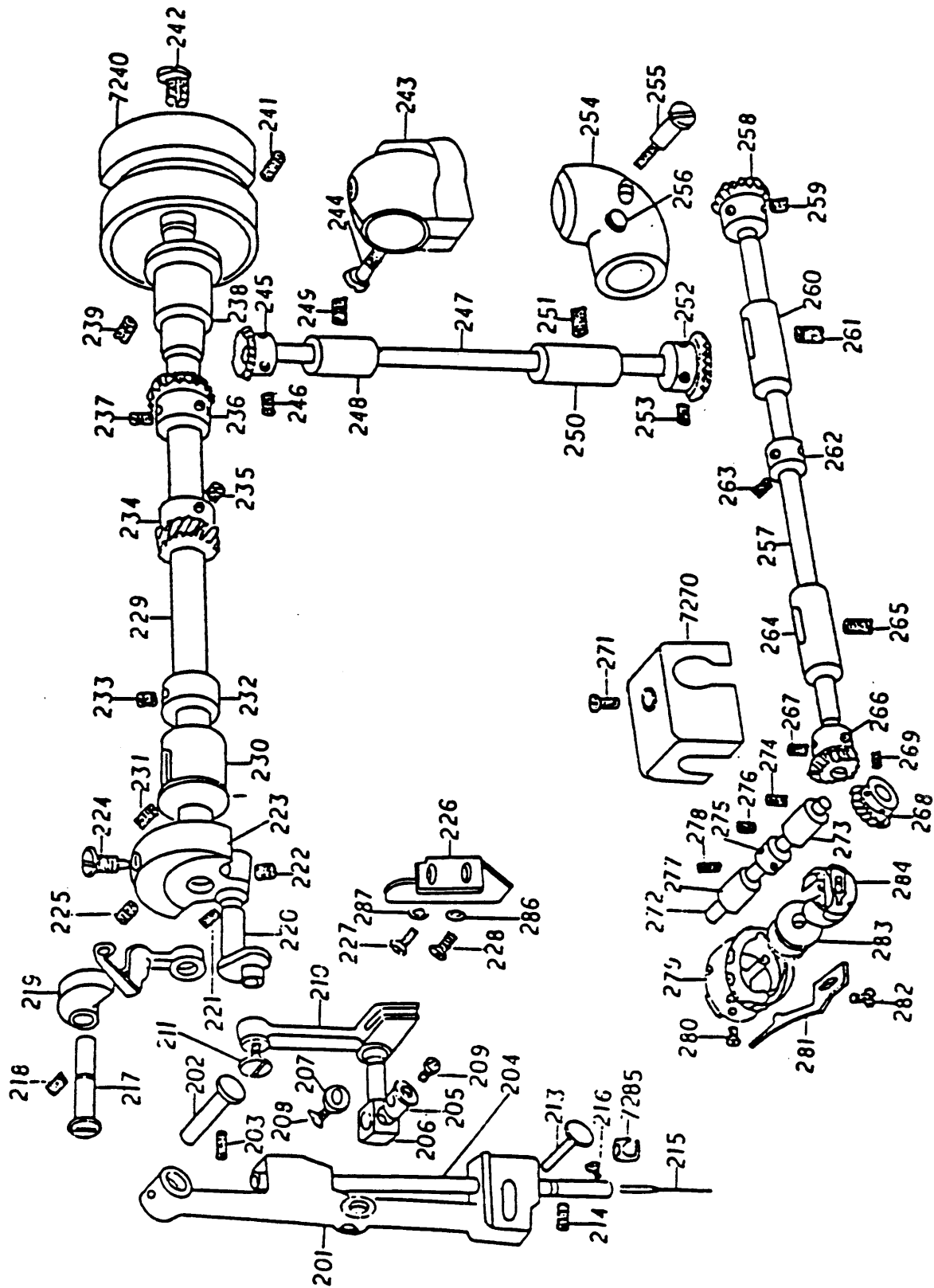



7.2.3. Width Mechanism & presser bar

ASSEMBLY NAME: M700 SEWING HEAD: ASSEMBLY FIG. NO.: 7.27  
 Zigzag Width Regulating ADDENDUM  
 Mechanism Components & Presser  
 Bar Assembly

REF.	QTY.	PART NO.	DESCRIPTION
301	1	P312301	Presser Bar Lifting Stud for Cam
302	2	P312302	Screw
303	1	P312303	Presser Bar Lifting Stud Holder
304	1	P312304	Presser Bar
305	2	P312305	Screw
306	1	P312306	Presser Bar Lifter Screw
307	1	P312307	Presser Spring
308	1	P312308	Presser Bar Lifter Lever
309	1	P312309	Screw
310	1	P312310	Presser Bar Guide Bracket
311	1	P312311	Screw
312	1	P312312	Presser Bar Lifter Lever Releasing Brkt.
313	1	P312313	Presser Foot
314	1	P312314	Screw
315	1	P312315	Eccentric Stud
316	1	P312316	Screw
7317	1	P312317	Needle Vibrating Cam Shaft
318	1	P312318	Collar (Rear)
319	2	P312319	Screw
320	1	P312319	Needle Vibrating Cam Shaft Bushing (Rear)
321	1	P312321	Screw
322	1	P312322	Needle Vibrating Cam Shft Bush. (Front)
323	1	P312323	Screw
324	1	P312324	Needle Vibrating Cam Shaft Bevel Gear
325	2	P312325	Screw
326	1	P312326	Needle Vibrating Cam
327	1	P312327	Screw
328	1	P312328	Cam Shaft Bushing (Front)
329	1	P312329	Screw
330	1	P312330	Cam Shaft End Screw
331	1	P312331	Needle Bar Frame Pit Man
332	1	P312332	Spring (Small)
333	1	P312333	Screw
334	1	P312334	Spring Hook
335	1	P312335	Lifting Spring
336	1	P312336	Catcher Screw
337	1	P312337	Zig-Zag Regulator
338	1	P312338	Screw
339	1	P312339	Slide Block
340	1	P312340	Stud
341	1	P312341	Nut
342	1	P312342	Holder
343	1	P312343	Screw
344	1	P312344	Zig-Zag Regulator Bushing
345	1	P312345	Screw
346	1	P312346	Zig-Zag Regultor Shaft

7347	1	P517347	Indicator
348	1	P312348	Screw
349	1	P312349	Washer
350	1	P312350	End Screw
7351	1	P517351	Zig-Zag Indicator Plate
352	4	P312352	Screw
353	2	P312353	Stopper
354	2	P312354	Washer
355	2	P312355	Nut
7356	1	P517356	Zig-Zag Connector
357	2	P312357	Screw
7358	1	P517358	Lifting Crank Shaft
7359	1	P517359	Lifting Crank
360	2	P312360	Screw
361	1	P312361	Indicator Stop Lever
362	1	P312362	Screw
7363	1	P517363	Bracket
364	2	P312364	Screw
365	1	P312365	Adjusting Screw
366	1	P312366	Nut
367	1	P312367	Lifting Rod
368	1	P312368	Cotter Pin
369	1	P312369	Stabilize Plate
370	1	P312370	Screw
371	1	P312371	Lifting Rod Roller
372	1	P312372	Screw
7373	1	P517373	Washer for 343



