



No. ED24030343-00E

Technical Information

Barudan

Subject	Spool holder change on KT-S1501CAII and KT-S1501CBIII		
Date Issued	19 th Mar 2024	Page	1/2
Model	KT-S1501CAII / KT-S1501CBIII	Class	Mechanical

BAJ Ref: RC0264

The spool holder has changed on the KT-S1501CAII and KT-S1501CBIII machines.

❖ Details :

When replacing a thread cone, the cone can be easily accessed from the front of the machine, improving work efficiency.

*KT-S1501CBIII 360X1200 is not supported.



👉 **KT-S1501CAII / Change over: H0233/Sn:3137432B24 or newer**

Old			New		
Parts No.	Descriptions	Q'ty	Parts No.	Descriptions	Q'ty
NH710090	Spool holder base (S1501CA2)	1	NH710130	Spool holder spacer (KT-S1501CA2)	1
NH710100	Spool holder support stay(S1501CA2)	1			
NJ710000	Spool holder ASSY (KT/KY-S15)	1	NH710110	Spool holder ASSY (KT-S1501CA2)	1
RD720000	Threading wire	1	NK710120	Threading wire (long)	1

👉 **KT-S1501CBIII / Change over: H0245/Sn: 3137421B24 or newer**

Old			New		
Parts No.	Descriptions	Q'ty	Parts No.	Descriptions	Q'ty
NF250171	Top cover (S15)	1	NK250060	Top cover(S15)	1
NK710001	Spool holder ASSY (KT-S15)	1	NK710090	Spool holder ASSY (KT-S1501CB3)	1
RD720000	Threading wire	1	NK710120	Threading wire (long)	1



No. ED24030343-00E

Technical Information

Barudan

Subject	Spool holder change on KT-S1501CAII and KT-S1501CBIII		
Date Issued	19 th Mar 2024	Page	2/2
Model	KT-S1501CAII / KT-S1501CBIII	Class	Mechanical

BAJ Ref: RC0264

❖ Installation of spool holder :

The spool holder ASSY for the KT-CAII and KT-CBIII are different, as seen by the appearance of the spool holder bases shown below.

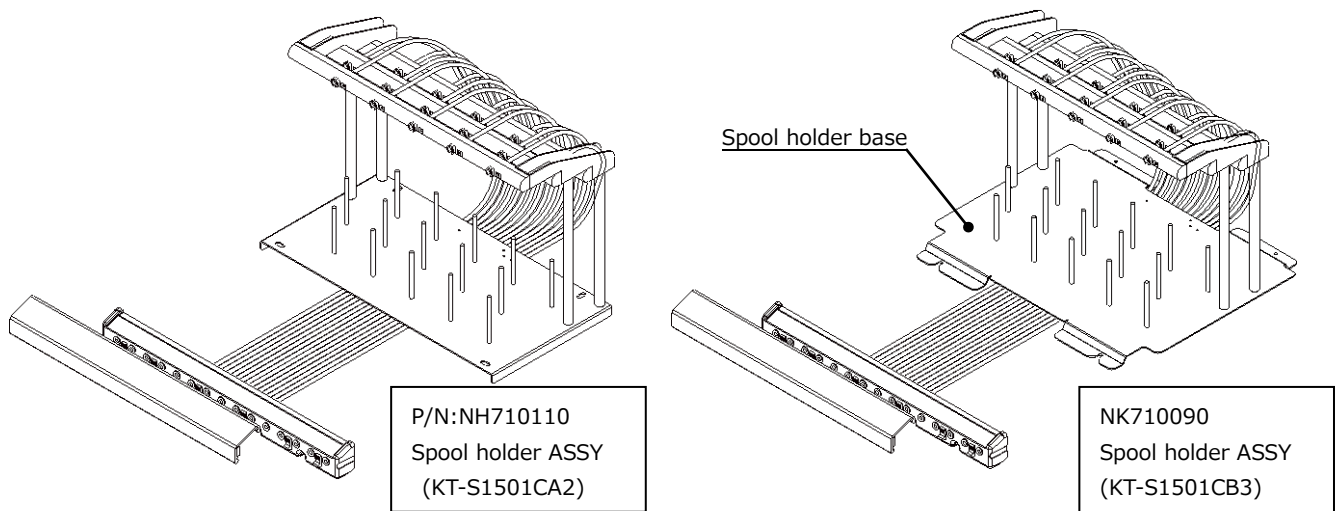

☞ For the KT-CAII

- 1) Set the spool holder ASSY on the spool holder spacer and attach with (4) M6X12 truss head screws.
- 2) Attach the thread collar base ASSY to the tension ASSY with (4) M3x8 Hex. socket bolts.

☞ In case of KT-CBIII

- 1) Set the spool holder ASSY on the top cover and attach it with (4) M5x8 truss head screws.
- 2) Attach the thread collar base ASSY to the tension ASSY with (4) M3x8 Hex. socket bolts.

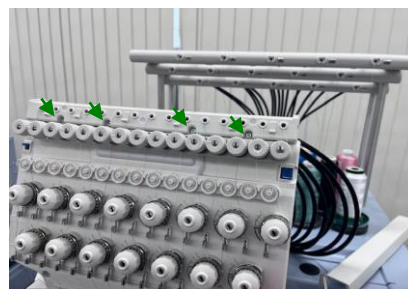

END